

MANUAL



Project. Alberto Garcia Interior Design

20
25



Tarimatec

WWW.TARIMATEC.SE

INDEX

Deck	4
Cleaning instructions	27
Mont Blanc	30
Annapurna	37
Aris	47
Malibú	59
Edge profile	65
Annapurna 50x30	71
Warranty	78
Finish	80

Project

Jaime Salvá Arquitectos

Photograph

Tomeu Canyellas



INSTALLATION

DECK



Assembly instructions

These assembly instructions have been designed to enable the proper installation of Tarimatec®, to ensure that you can enjoy your product with guarantees of complete durability and good performance.

It is necessary to follow these instructions to ensure the good performance of your Tarimatec® installation. Please read the instructions before installation.

Project
PIA Paisajismo
Photograph
Nacho UribeSalazar

Floor condition

The floor where Tarimatec® is to be installed must be solid and in good condition, preferably hard and rigid, it should not crumble (e.g. concrete) where the fastening batten can be screwed down. The floor must ensure water drainage so the deck is kept from flooding.

If the risk of water leaks prevents the use of screws, or if the floor conditions do not allow for it, a closed structure must be built using the framing squares as detailed further along in this manual.



1. Swimming pool with concrete floor, example of floor suitable for screwing.

Battening



2. Batten A (30 x 50 mm).

Batten type

Battens are the **internal attachment structure** of Tarimatec®. It should be noted that the batten framework should not be considered as a structural element in itself, and should always be installed on the ground, on plots, concrete tiles or other type of main base or structure. These battens are manufactured with a special aluminium alloy, which offers excellent all-weather performance.

Batten installation and calculation

The first question we have to ask ourselves to carry out a good installation is: What is the surface on which I want to install Tarimatec® and what is it like? Once this question has been answered, it is advisable to make a plan or sketch of the surface to be installed that shows the layout of the battens. For this, the information detailed below must be considered:

The battens must be placed perpendicular to the direction in which the deck is to be installed. The maximum spacing between centres should not exceed **350 mm** in mild climates. This spacing should not exceed 250 mm in tropical climates. Later on, the batten installation concerning the beginning and end of the process, as well as in the meeting points between deck headers, will be covered in more detail. The battens must be screwed to the floor or support base

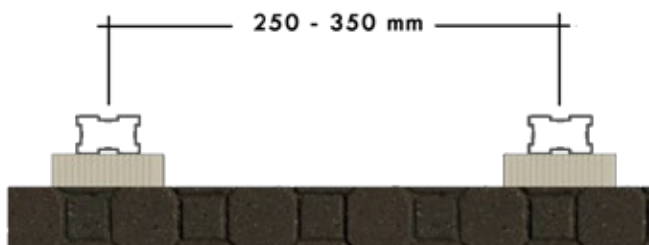

3. Spacing between battens.

using stainless steel drive anchors of at least 6 mm section, suitable for outdoor use. The standard available measurements offered by Tarimatec® are **6 x 60 mm** and **8 x 100 mm**. It is possible that, due to the nature of the soil, another type of fastening may be required, which under no circumstances will have a lower performance than that indicated here.



4. 6x60 mm and 8x100 mm drive anchors

This screw should be fitted to the inner side of the batten to ensure maximum ground penetration and the best possible anchorage. The battens **should never be supported directly on the floor**, but on rubber wedges or joints at least **10 mm** high, to enable drainage of accumulated water. These wedges can be made out of Tarimatec® cuts.

Tarimatec® can be cut to the desired size and shape. Its structure and composition make it suitable for use as a levelling wedge with the warranty that Tarimatec® is a perfectly weather-resistant product. Wedges can be glued to the floor with an **MS** type adhesive, suitable

for outdoor use, resistant to water and UV radiation. Using adhesive to fix the wedges **does not mean** that the battens should not be screwed to the floor or that a closed batten structure should not be carried out. Minimum penetration length of the screw into the ground is **50 mm** in order to ensure the correct fixing of the batten to the floor. In addition, the ground must be sufficiently rigid and stable to support the expansion of the screw anchor without cracking. **Depending on the nature of the floor, the site project management may modify the type of anchoring to ensure the stability of the batten structure.**



5. Batten screwed to the floor on a deck wedge.

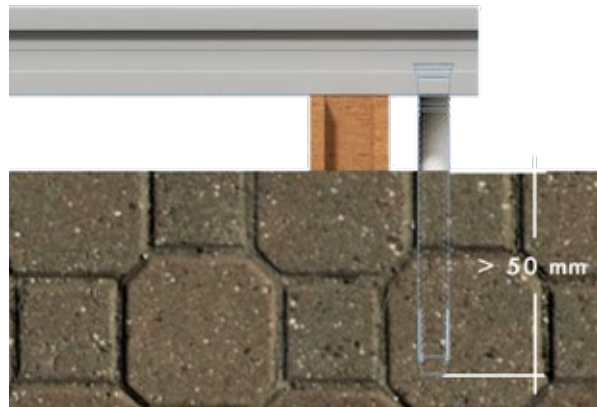

6. Minimum screw penetration distance into floor.

The spacing of the fixing screws attaching the batten to the ground, as well as the support wedges, should not exceed **500 mm**. In tropical climates, the spacing of the fastening screws should not exceed 350 mm.

7. Distance between batten anchor screws and floor.

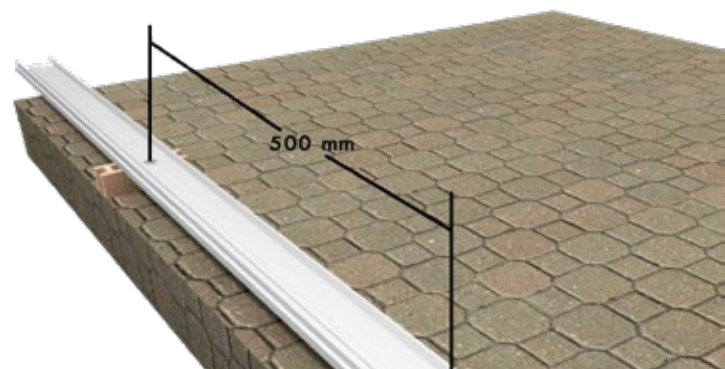

If, as previously seen on images, levelling is required, the use of **Tarimatec® cuts**, PVC wedges, or other weather-resistant material, is recommended. For elevations above **150 mm**, the use of **Tarimatec® plots** is recommended. The maximum spacing between the plot centres must be at least **600 mm**.

The plots supplied by Tarimatec® have a **clip or anchoring system** that ensures the attachment of the batten to the plot.

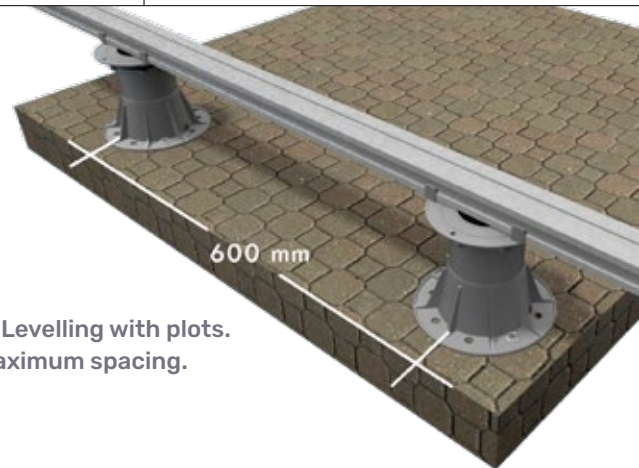

8. Levelling with plots.
Maximum spacing.

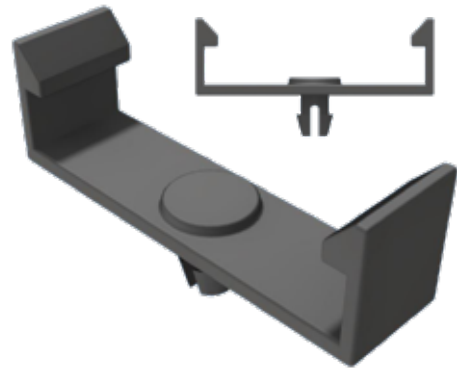

9. Batten-plot anchor clip.



The plots used in the assembly, as is the case with the batten installed on wedges, **must be fixed to the floor** using penetrating drive anchors of, at least, **50 mm**.

Depending on the nature of the floor, the site project management may modify the type of anchoring to ensure the stability of the batten structure.

10. Detail of plot-batten anchoring. Detail of plot attachment with drive anchors.

On the other hand, a minimum spacing of **3 mm** must be left between the batten headers. That is to prevent the impact between them due to linear thermal expansion. This spacing must not coincide with the space where the screw of a clip would be installed, preventing it from being fastened to the batten.

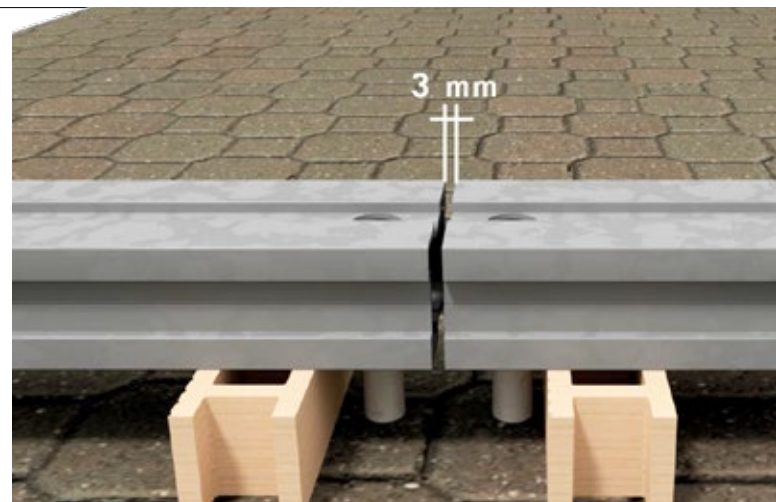

11. Spacing between batten headers

At this point, the next question to be asked is: **How should the batten installation be carried out?**

This depends on several factors:

- *The floor where Tarimatec® is to be installed (it can or can't be screwed in)*
- *The length of the slats and the drawing that the design of the slats will create.*

As for the floor:

- Screws must be used as long as the floor permits (be it rigid and not susceptible to crumbling), as well as there being no danger of leaks or seepage into enclosures below.
- In floors where screwing or gluing are not permitted, as for example on soil or garden lawn floors, concrete slabs with a minimum dimension of **400X100X40 mm** should be set down and a closed structure like the one shown in the following image as an example should be assembled. The gap between tiles should never exceed **500 mm**. Over these tiles, we could now screw in the batten. In attics or places where **screws are not supported**, a **closed structure** should be created in the same way, and supporting it on plots or another levelling element of those described above.
- The separation between ties shall not exceed 900 mm, assembled to the main battens with brackets as will be seen below.



12. Batten installation with tiles.

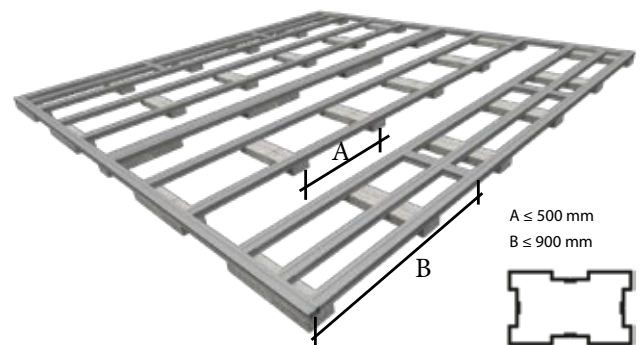

13. Maximum span, tile separation depending on batten type.

For the assembly of a **closed structure**, the perpendicular perimeter battens, and the braces are joined using **Tarimatec® joining brackets**. In order for the framing square to be able to offer all its features, it must be inserted in the battens' side grooves, as shown in the image. For fixing, the same screw used in the clips shall be used.

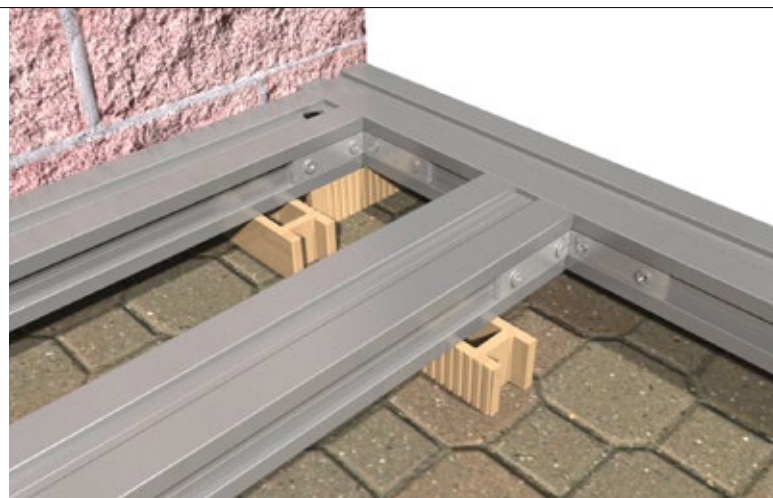

14. Batten connection with framing squares.

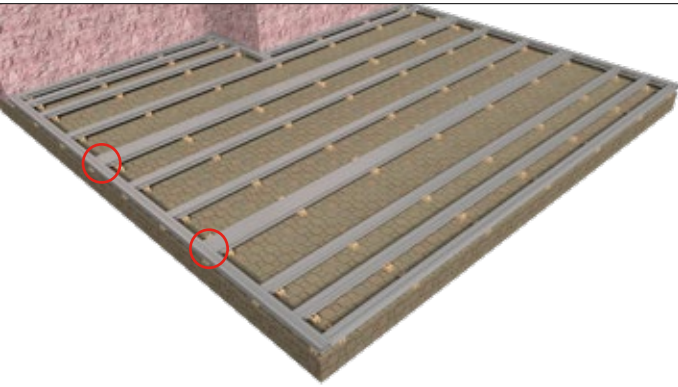

15. Batten structure for an intermediate header meeting point.

In terms of slat length;

- The slat length will define the batten installation design or, on the contrary, the batten installation design will define the slat length.

As shown in the drawing, the battens must be bent at the beginning and end of the installation. This point is very important to ensure the stability of Tarimatec® during the installation.



There must always be two battens installed in all internal and external perimeter areas of the installation.

Consider that **two battens should be installed between Tarimatec® headers**. For this reason it is advisable to design the batten installation according to the placement of headers on the decks.

If the slat length covers the installation width, the two battens marked with a red circle would not be required, as shown in drawing 15.

The example in figure 16 shows that the slats used are shorter than the installation total width; hence, two battens must be used where the headers meet for a fastening clip to be placed at the end of each slat as shown in the following figures.

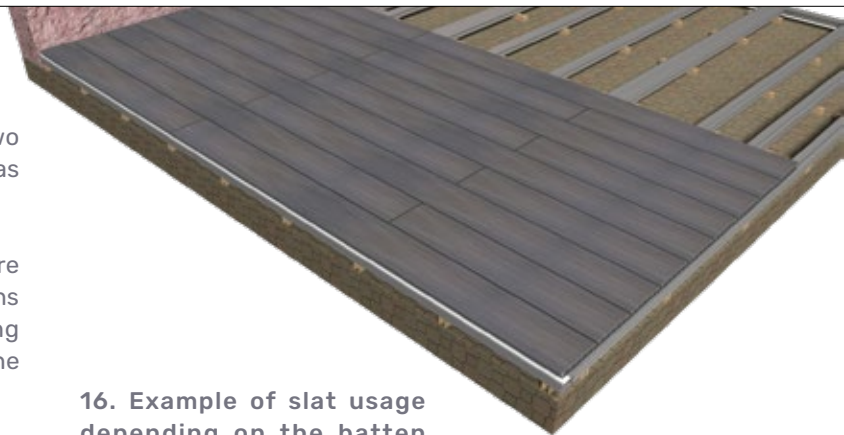

16. Example of slat usage depending on the batten installation.

The slats are fastened with an **original Tarimatec® clip** screwed to the aluminium batten with a 25-millimetre self-drilling stainless steel screw supplied by Tarimatec®.

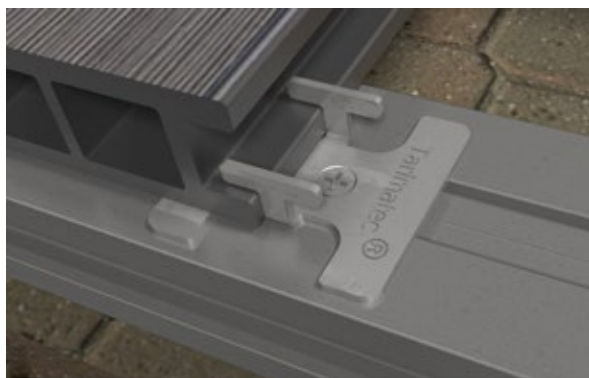

17. Details of slat fixing with a clip

As mentioned before, two battens and a clip are used for each header where the deck headers meet. The slat fixing detail is shown in the following figure:



18. Installation of two battens between headers with a clip for each slat.

As previously indicated, the ends of the installation must have an intermediate batten, ensuring that the distance between the **first and second batten does not exceed 150 mm**, and the distance between the **first and third battens, does not exceed 350 mm**. As previously indicated, understand "installation ends" as the perimeters where all the ends of the boards finish, whether on a wall, a pool basin, etc.

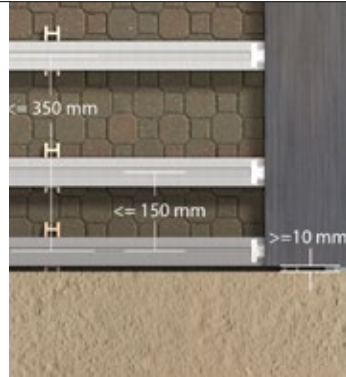

19. Distance between battens at ends

20. Details of the slat installed in installation-end battens.



As an example, and to clarify the concept of two battens in areas where deck headers meet, as well as the intermediate battens at the ends of the installation, the following illustration shows all the possibilities of slat length and arrangement, depending on the batten installation.

The example shows the intermediate batten at the ends, as well as the double batten where the Tarimatec® headers meet.

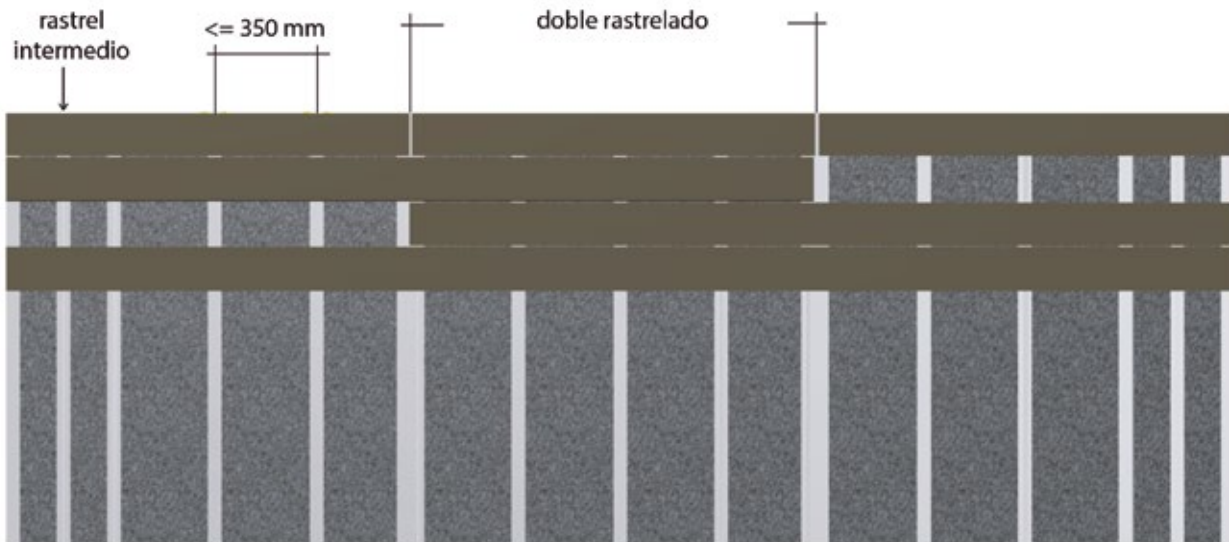

21. Batten installation with different-length slats.



Correctly applying and installing the battens will result in a successful and adequate performance of the product. A closed structure with brackets, whether it can be screwed or not, is always recommended to facilitate levelling, installation and stability over the years.



22. Batten installation for an invisible joint.

Tarimatec® recommends installing the slats with a **regular joint**, as will be seen in the following sections, but in specific cases, in which, due to the complexity of the pattern made by the flooring joints, such as when installing with a hidden joint, a double batten cannot be placed where the ends meet, the two clips must be placed on the same batten, as shown in the photographs:



23. Double-clip batten.



24. Assembled deck with invisible joint.

Once the batten installation design has been defined, as well as how and what elements should be used to level it, and which drive anchor to be used to fasten the installation to the floor, the question is:

Which tool to use to drill the batten and the floor, and how to place the screw-plug inside the inner batten wall?

The following steps are the answer to that question:

- 1st. Drill two holes; one on the upper side and another one on the underside of the batten. The upper hole must have a larger

diameter than the bottom hole, since the screw plug has to pass through it completely to be able to rest on the bottom hole. This way, the tip of the screw and its plug will pass through the bottom hole, but not the head, which will remain as a fixing element between the batten and the floor.

This can be done by drilling two holes with different-diameter drill bits or by drilling a single hole if a dual-diameter drill bit is used. The drill bits section must correspond to the type of fixing screw used for securing the battens to the floor.



25. Dual diameter drill bit

As shown in the image, once the holes are made, the batten will have two, the upper one which has a larger diameter (**A**) than the lower one (**B**) that, as previously mentioned, allows the nail plug to completely enter, while the lower one only allows the screw and plug body to go in but not the head.

- Secondly, using a drill bit suitable for concrete and matched to the size of the anchor screw we need to use, proceed to drill the floor through the holes we made previously, to the necessary depth so that the anchor can be completely accommodated. We remind you that **50 mm** is the minimum depth the anchor screw must penetrate into the ground. As already indicated, this distance may be greater depending on the type of soil and will be determined by the project supervisory team.

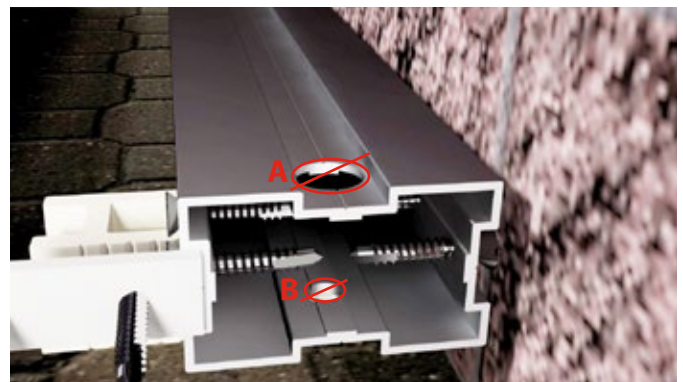

26. Different-diameter holes in the batten.

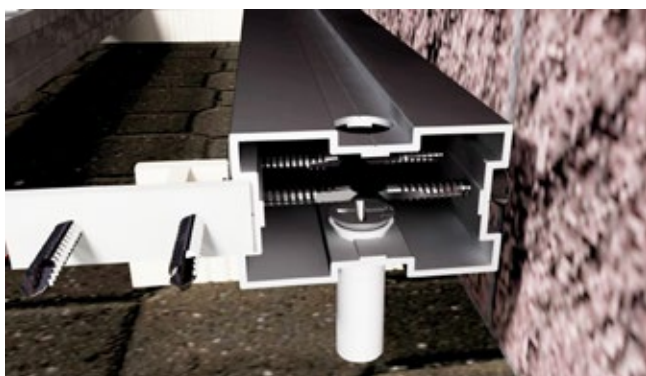

27. Hole in an aluminium batten and in a screw plug.

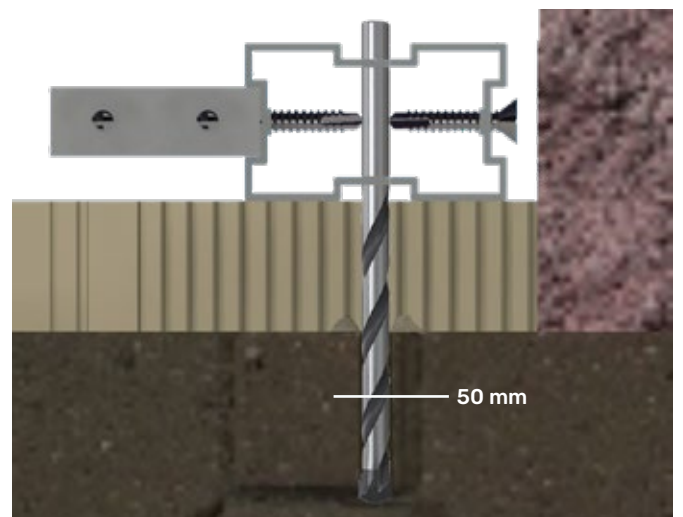

28. Floor hole with concrete drill-bit.

Using an extra tool or a drive pin, hit the screw to drive it inside the floor, fastening the batten from its lower side.

The screw head must not be damaged for it to be unscrewed easily if needed.

Framing squares will be installed on each side at every corner of the installation from the outermost battens of the batten installation panel. This will ensure the stability of the closed panel or structure. This shall also be done if tie rods are required because it is not possible to bolt the structure to the ground.

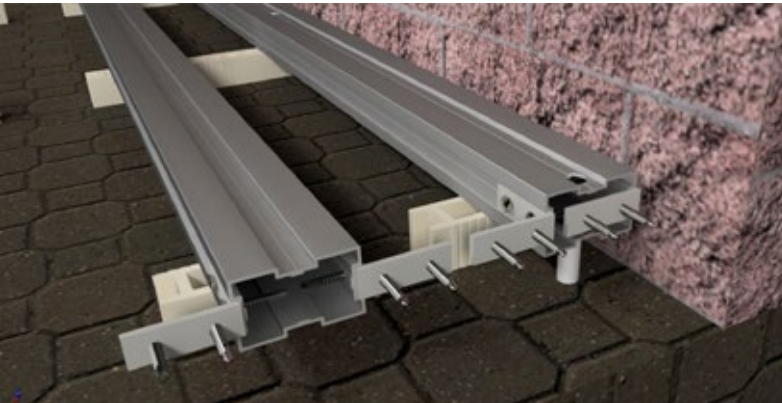

29. Section view of batten fixed with drive anchors to the floor and aluminium framing square perimeter battens.

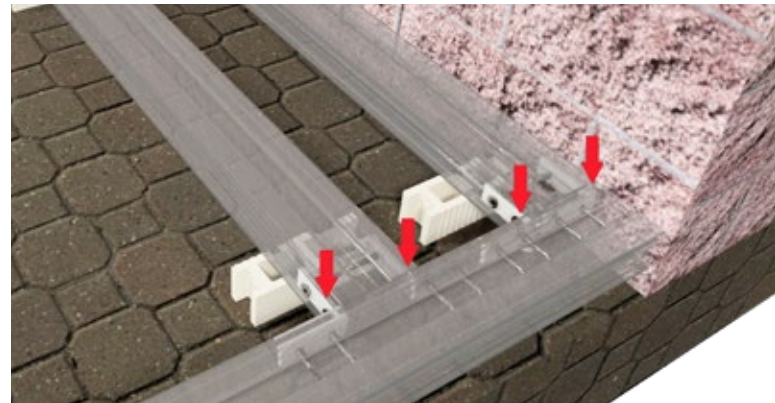

30. View of the perimeter framing squares fixed to the longitudinal perimeter batten.

Installation of Tarimatec® Deck

The installation of Tarimatec® Deck is straightforward, but several aspects must be considered to ensure a perfect installation.



It is advisable to leave the deck on a **smooth and flat area, protected from direct sunlight, 48 hours before its installation.** Tarimatec® must not be installed if temperatures are lower than 0° C.

If the batten installation where the deck will be placed has been correctly made and levelled, it will be flat and solid, and have a slight 1% inclination to let water flow. **Efficient water drainage, as well as good ventilation, above and under the deck must be ensured.**

In facilities where more than one pallet is supplied, **mixed boards from different pallets must be taken during installation.** This will give our installation more liveliness and prevent marked differences between panels.

Beginning the installation

Once we are certain about which side of the battens we will start installing Tarimatec® Deck, this is done using the Tarimatec® initial clip.

31. Initial clip screwed to the perimeter batten

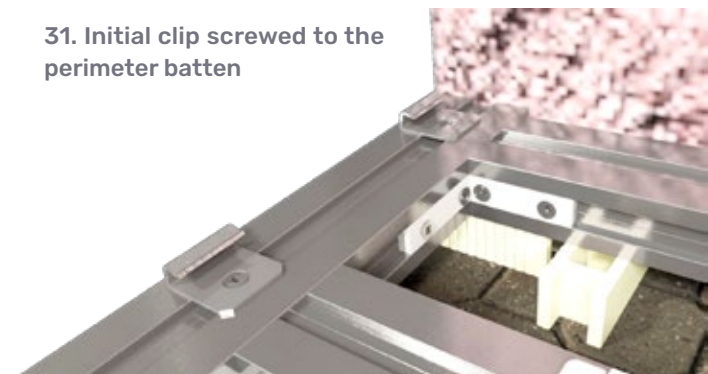

The initial clip will provide grip on the slat end that is closer to the wall or the edge where the installation was started.

The initial clip must rest on each batten above the perimeter batten or, as shown in this example, at the same height as the battens placed crosswise to the slat. The initial clip is screwed using the same fastening screw (4.2x 25 mm) for the clip and the Tarimatec® framing squares.

The initial clip hole must be centred on the batten, so that the distance between the batten side and the clip is approximately 6 mm.

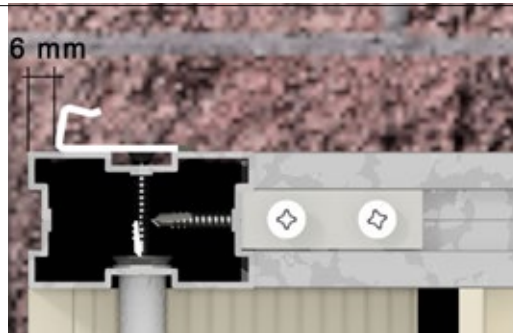

32. Detail of initial clip side view

33. Starting the installation with the initial clip.



Alternatively to the starter profile, the F aluminium profile can also be used, which is also screwed to the perimeter batten.

Regarding the fitting and layout of the Tarimatec® installation, the recommended design features regular joints, as shown below.

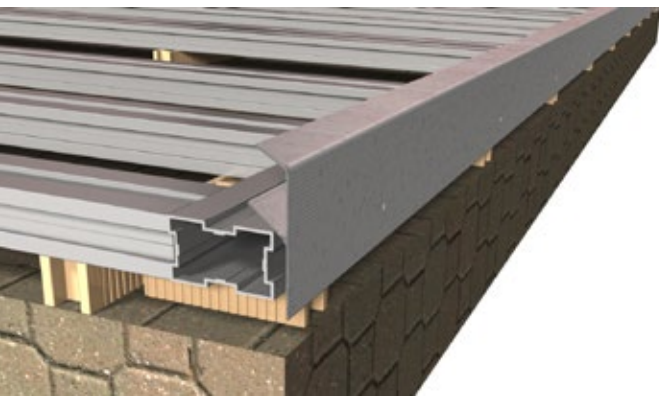

34. Starting the installation with F profile

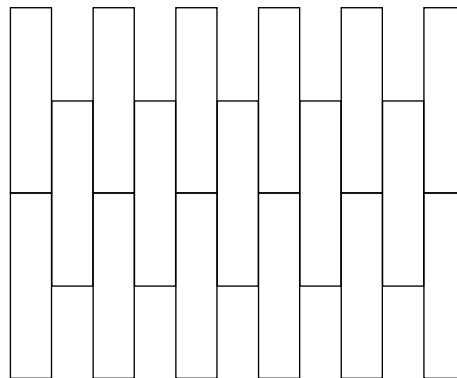

35. Normal joint

As mentioned before, the selected design will define the batten installation. Once the initial clips or the F profile have been placed, the slats should be installed, trimming the pieces with a mitre saw or a portable guided circular saw to the desired size. Even if the Tarimatec® slats were ordered with a specific size based on the slats-to-be -installed length, we will **always** have to make a final on-site adjustment during the installation.



36. Mitre saw



37. Manual guided circular saw

Once the first Tarimatec® slat has been placed, fasten it from a side using an initial clip or the F profile, and on the other side, place and fasten a clip on every aluminium batten to secure the slat.

It is advisable to place the screw in the hole slightly off towards the deck side to make sure that, when the countersunk part reaches the clip, it pushes the screw towards the deck, making the clip legs fully touch it. We must **prevent the legs from coming into to contact with the deck clamping wing**, to ensure the flatness or straightness of the installation. Each batten must have at least one clip.



38. Separation of the headers from the deck with regard to the wall.

It is very important to take into account that, for installed profiles that end at a wall or installation perimeter, there must be a minimum gap of 10 mm at the end.



39. Fastening the deck with Tarimatec® clips



As in the case of the wall, it is also necessary to separate the slats from the headers, although in this case the separation must be at least **5 mm**.

This separation is **calculated for slats up to 2.5 m** long. *For longer slats, this gap between the ends will increase proportionally (e.g. 6 mm for 3 m slats).*



40. Spacing between headers

For a proper installation result, and regardless of the Tarimatec® laying pattern chosen, the misalignment of **the slat headers with regard to the batten must be avoided**.

To guarantee its dimensional stability, a Tarimatec Deck slat must be supported on at least 3 battens.



41 Clip and stainless steel screw on an aluminium batten. Deck header resting on the batten.



Orientation of the decks

When installing the flooring, it is very important to follow the pattern for placing the slats, always leaving the inner partition **indentation**

placed in the **same direction**. The final result of the installation may be greatly affected if the pattern is not followed.

42. Correct installation direction of indentations

Indentation 



Corner mounting

During the installation, it is common to find more challenging areas in which to work, such as corners or projecting or hollow sections. Tarimatec® offers a great variety of products for these scenarios, as the material is very easy to work with, being able to be shaped to fit each specific installation area,

since it can be trimmed without losing any properties. The example shows a corner in which the full width of a complete piece of Tarimatec® does not fit, thus, the part must be trimmed to fit where it is going to be placed.



43. Installation corner.



44. Gap for placing the slat. Detail.

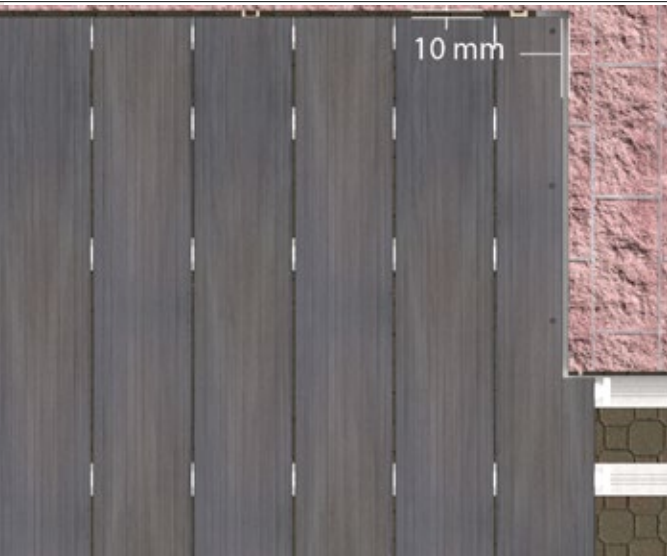

As shown in the image, the side of the slat that cannot be fastened using clips is screwed to the batten with a stainless steel screw that runs through the Tarimatec® slat and the aluminium batten.

The height difference between the slat side with the clip installed compared to the one without one must be levelled by placing a wedge or a stopper with the same thickness as the clip (1.5 mm) between the slat and the batten in the specific mark made for the slat to be perfectly levelled. As with the deck headers, the spacing from the wall must be 10 mm.

The previous photograph shows a top fastening solution with an exposed screw. Solutions with a concealed finish can be executed in two ways:

- With hidden clip.
- With concealed screw.

46. Trimmed-slat corner assembly

1. Solution with hidden clip

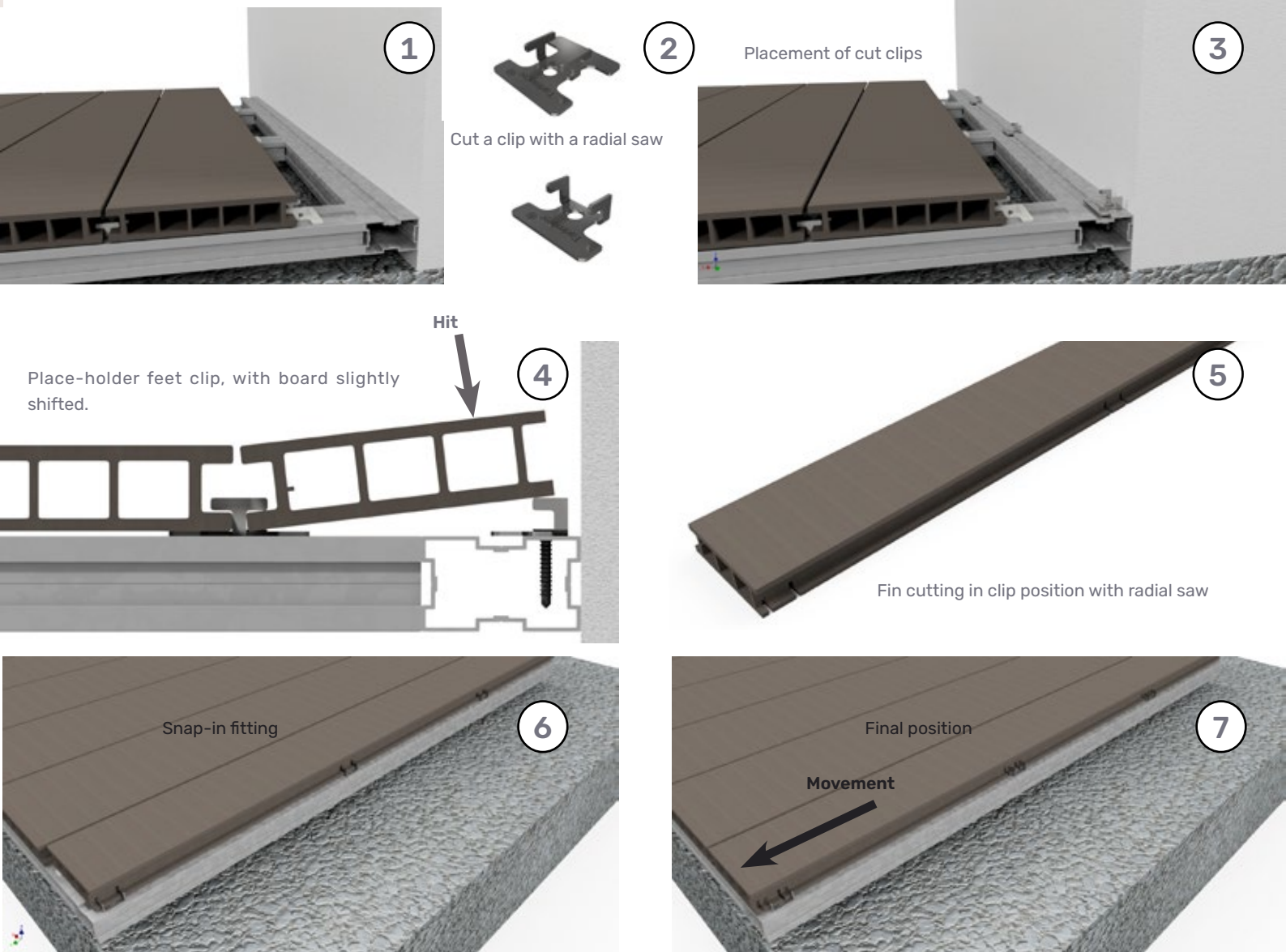

47. Hidden fixing sequence with clip.

2. Hidden screw solution

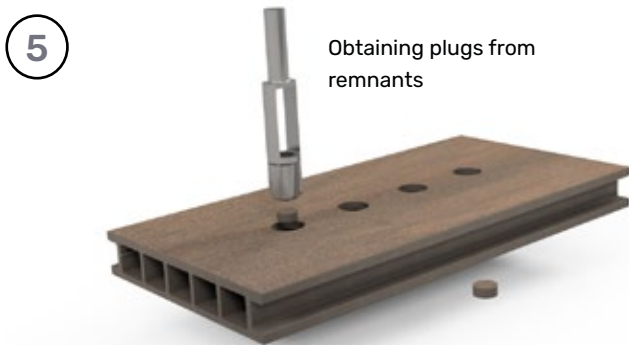
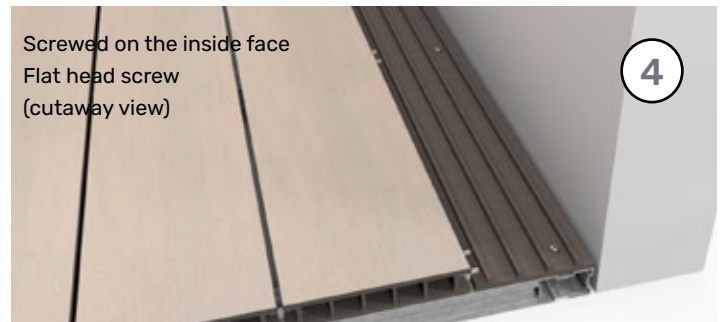
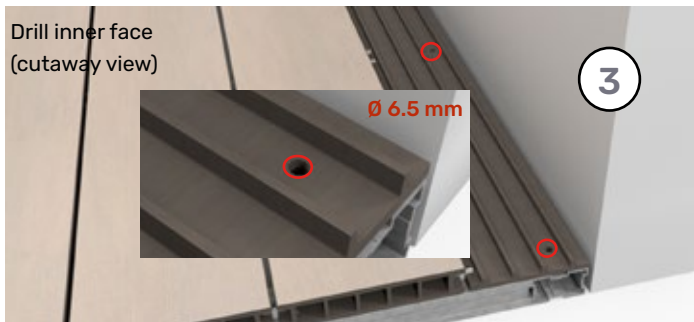
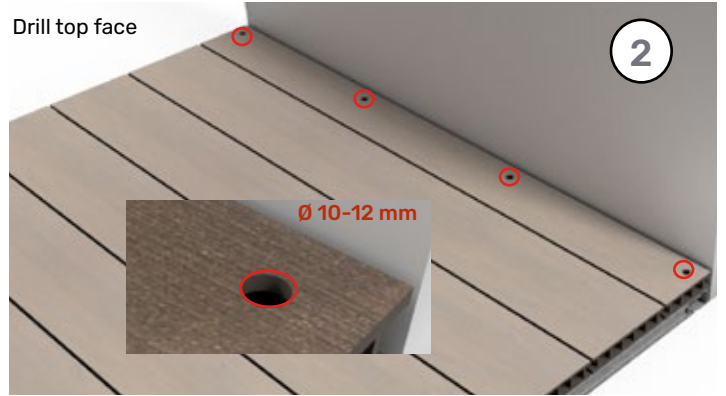
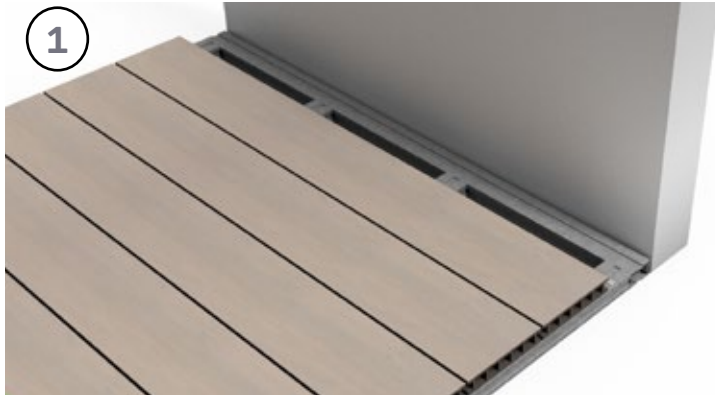

48. Hidden fixing sequence with screw.



The **torque of the screws** should be sufficient to secure them, but **without embedding the screw**, allowing for the normal expansion and contraction movement of the decking.

Having considered the possible solutions and resolved the corner, we continue installing the decking boards until reaching the last row, where, as is usually the case with corners, we will need to adjust and trim some boards to fit them at the end of the installation.

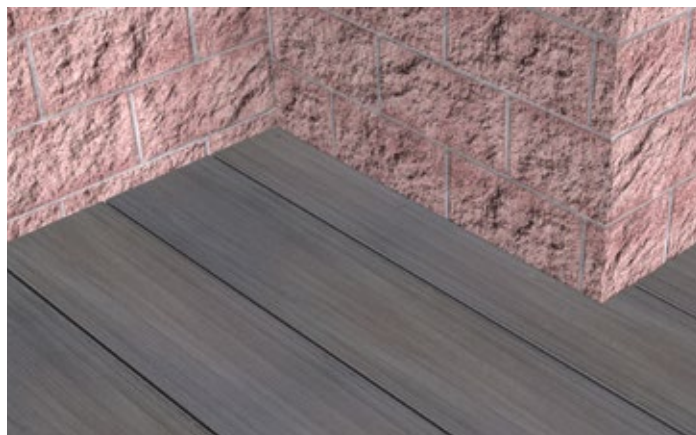

49. Assembled trimmed slat. Overview.



50. End of the installation

Completion of the installation

It is possible to plan the batten installation so that complete boards are used at the end of the assembly. However, this will not be a common scenario, thus, the end slats will need to be retouched, as in the example installation.

As already mentioned in previous sections, in addition to the flexibility Tarimatec® offers when working with its boards, it also provides several solutions to finish an installation, and these include the aluminium F profile or the initial/finishing profile.

Regardless of our choice, the first task is to cut the Tarimatec® slats lengthwise to adapt them and be able to install them on the available space.



51. Final details of the installation



52. End of the installation with slats cut lengthwise and in place.

Once the two pieces are placed, if the initial profile has been selected to finish the installation, it will be fixed using self-drilling screws. They must be screwed as shown in the

following image, so that the screws go through the slat, the initial profile and the aluminium batten, thus providing optimal support for these last boards.

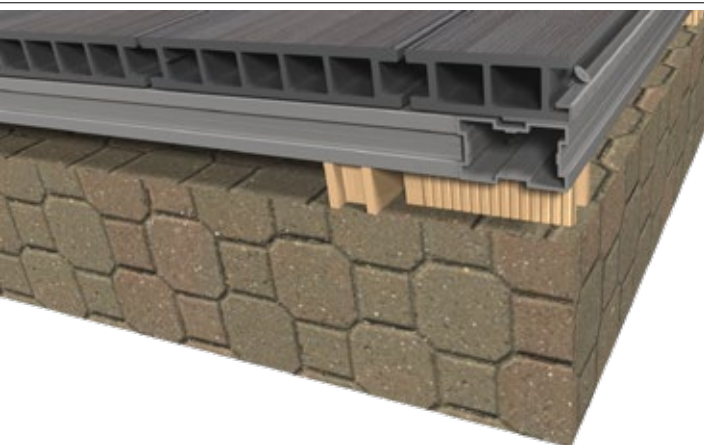

53. Detail of initial profile screwed into the batten.



54. Screwed initial profile holding the last strip of slats.

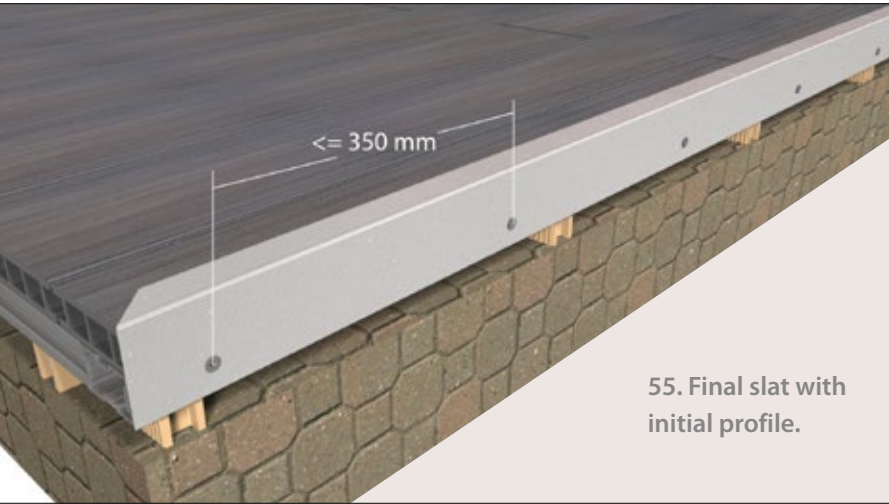

55. Final slat with initial profile.

Alternatively to the initial profile, the aluminium F profile can be used to both start and finish the installation. The F profile must be screwed to the perimeter aluminium batten, thus providing optimal fastening to the final slats strip. The separation between screws must not exceed **350 mm**. As shown in the image, the F profile does not cover the entire side of the installation. The way to improve the finish will be shown in the following section.

Finishes

Once the Tarimatec® slats installation is complete, there are several options available to top off the areas not ending on a wall that are still visible. These options include the end profile or cover, the aluminium F profile, aluminium F profile and cover, or the installation of a buffer stop, which is explained in another section of this manual.

A moulding is a top off piece that is manufactured with the same raw material and colours as the Tarimatec® slats, offering many possibilities, including shaping, to adapt it to rounded or other kind edges. This can be done using a heat gun to warm it up.



56. Hot-air gun



57. Shaped moulding



58. Assembled buffer stop

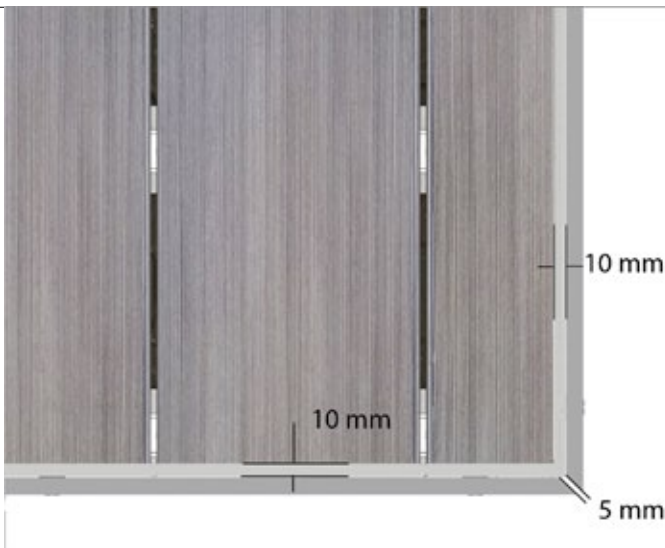

59. Moulding screw attachment to aluminium batten.

There are several factors to be considered in moulding assembly:

There must be a **5 mm** gap **between the moulding headers** to avoid collision if the pieces expand or contract. A separation of **10 mm** must be left between the headers and the sides of the deck and the moulding.

Holes must be drilled in advance to screw the moulding to the batten. At the **ends of the moulding**, a hole must be drilled using a $\varnothing 5.5$ mm drill bit. The rest of the holes must be made with a $\varnothing 10$ mm drill bit. The spacing between these holes must not exceed **500 mm**. To fasten the moulding to the batten, a specific coloured moulding screw must be used, which eases the expansions and contractions in a controlled manner, thus preventing deformations.

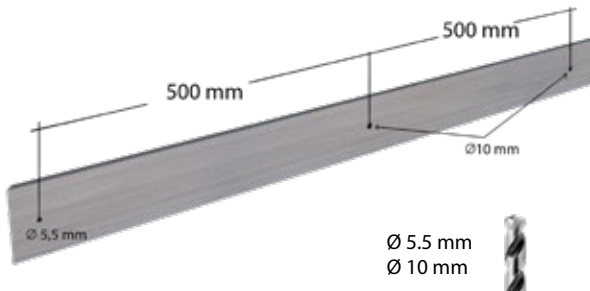

60. Hole diameter details and the spacing between them.



61. Moulding special screws details

Once placed, the separation between the moulding and the floor must be at least **10 mm**.

As seen in previous sections, good ventilation and water drainage under the installation is a necessary condition for a good deck performance, and this space favours these two aspects.



62. Minimum distance between the moulding and floor.

As shown in the image, the moulding must be screwed to the aluminium batten at the centre, leaving the upper side of the moulding at the same level as the deck surface.

63. Detail of the moulding screwed into the centre of the batten.

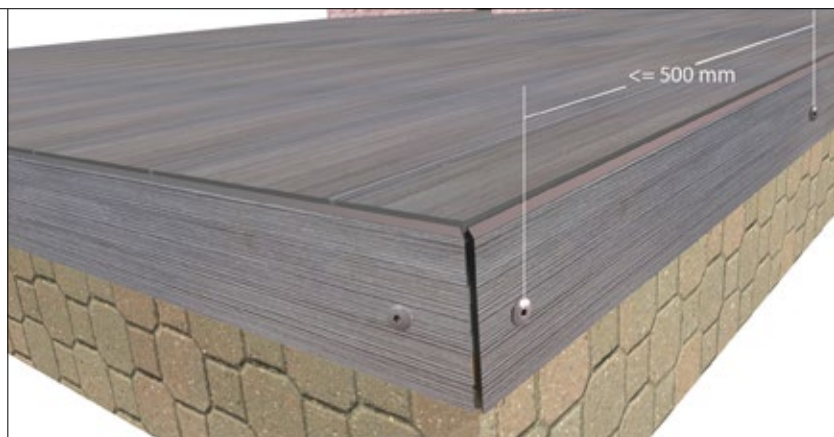
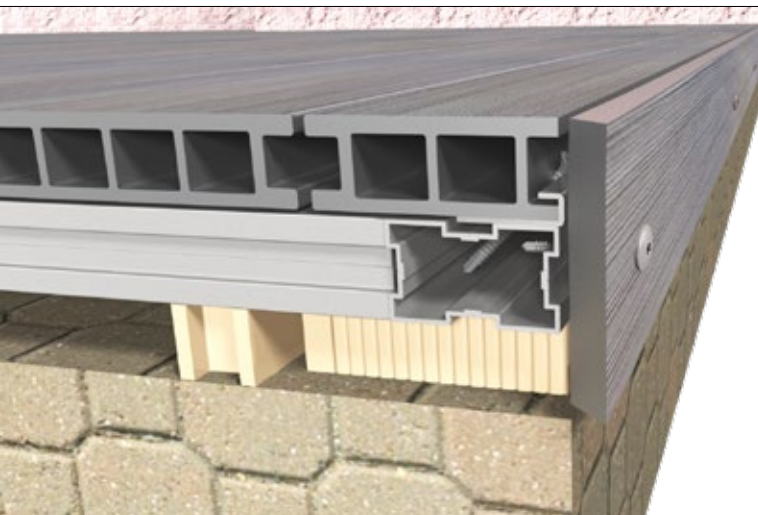

64. Maximum distance between moulding fastening screws and the batten.

As stated above, **the bolt spacing** should be a maximum of **500 mm**.

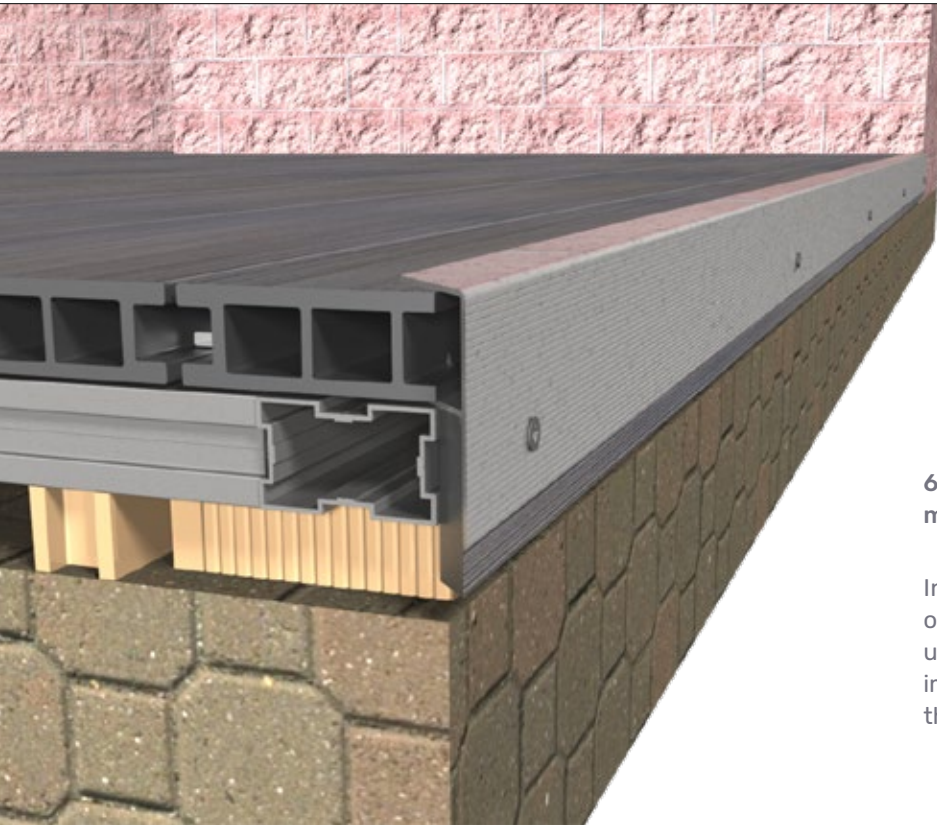

65. Detail of F profile screwed into batten and moulding screwed into batten.

In case the aluminium F profile is chosen instead of the initial profile, the moulding can be placed underneath the lower wing as shown in the following image. The screws hold the aluminium F profile and the moulding to the aluminium batten.

The separation distance between the moulding and the floor must be at least **10 mm** and, in this case, the separation distance between the aluminium F profile fastening screws and the batten must not exceed **350 mm**.

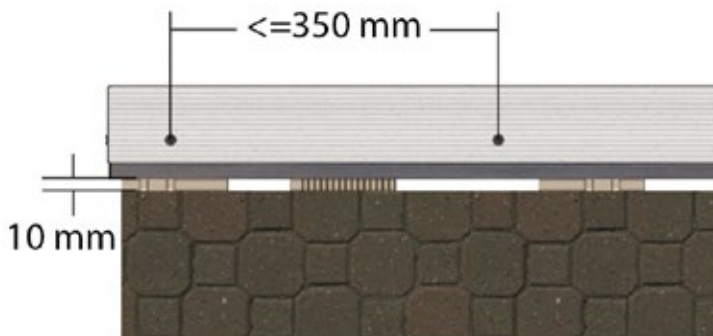

66. Moulding-to-floor distance and screw spacing

In addition, the separation distance between the deck header and the aluminium F profile front partition shall be at least **10 mm**.

67. Distance between the deck header and the F profile



The following image shows a different view of the separation between the deck and the aluminium F profile internal side.

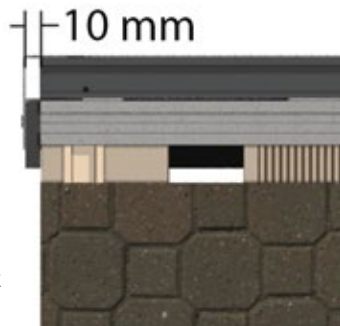

68. Distance between deck and F profile. Side view.

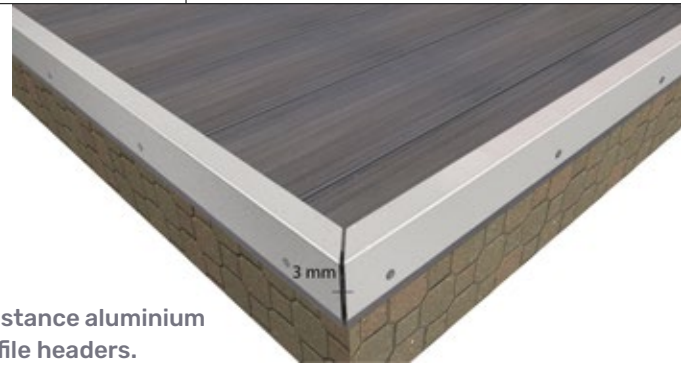

69. Distance aluminium F profile headers.

The distance between F profile aluminium headers must be at least **3 mm**.

General views of the installation finished with moulding and with aluminium F profile and moulding.



70. Complete installation topped with moulding.

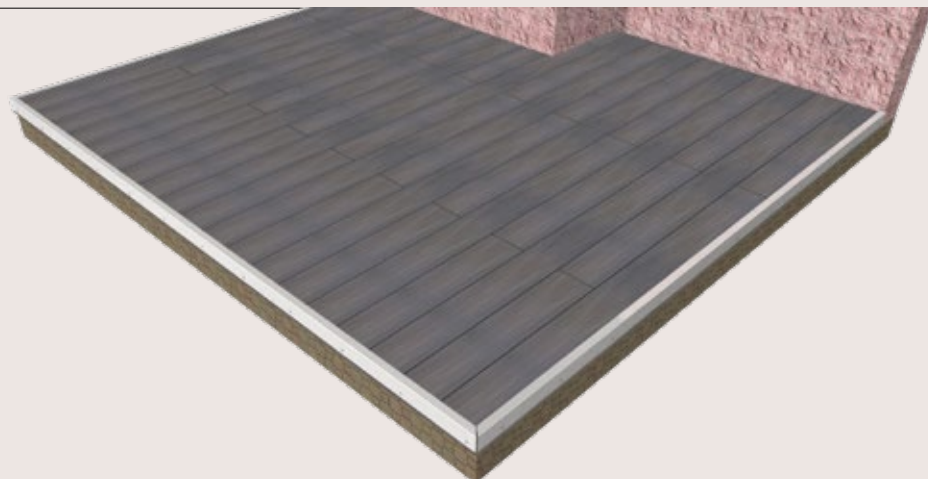

71. Complete installation topped with aluminium profile and moulding.



Platforms

TARIMATEC® CHROMATIC - WOOD - ETHNIC

DIMENSIONS

TARIMATEC® CHROMATIC TECNO / ETHNIC SURCO

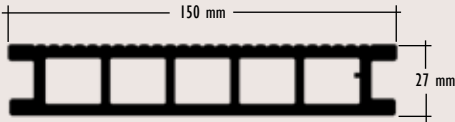

	TECNO / SURCO Value	Tolerance
Weight	2,625 g/m - 17 Kg/m2	± 100 g/m
Width	150 mm	± 0.5 mm
Height	27 mm	± 0.5 mm
Length	2,500 mm	± 10 mm

Total height of the hollow Deck system (not including levelling elements)



Total height of the solid Deck system (not including levelling elements)



TARIMATEC® CHROMATIC NATURE / MADERA NATURE

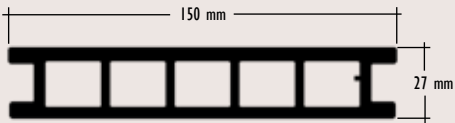

	TECNO / SURCO Value	Tolerance
Weight	2,625 g/m - 17 Kg/m2	± 100 g/m
Width	150 mm	± 0.5 mm
Height	27 mm	± 0.5 mm
Length	2,500 mm	± 10 mm

TARIMATEC® CHROMATIC NATURE / MADERA NATURE

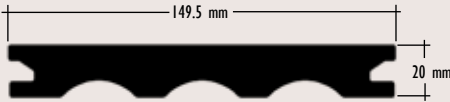

	TECNO / SURCO Value	Tolerance
Weight	3,650 g/m - 23.72Kg/m2	± 100 g/m
Width	200 mm	± 0.5 mm
Height	27 mm	± 0.5 mm
Length	2,500 mm	± 10 mm

Weights m2 Systems*

- Hollow deck: 19.5 Kg/m²
- Solid deck: 26.22 Kg/m²

Calculated including the corresponding deck profile, battens, fixing clips, and fasteners. The weight of any levelling or jointing elements for battens has not been considered.

For calculation estimate 6.5 mL/m² at 150 mm width. Customised lengths possible, from 100 m², maximum length 4,000 mm.

PHYSICAL AND MECHANICAL PROPERTIES	MET. TEST	TECNO/NATURE/SURCO	MACIZA
Coefficient of linear expansion	UNE 53126	2,81·10 ⁻⁵	
Modulus of elasticity	UNE-EN ISO 178	4,660 Mpa	
Bending strength	UNE-EN ISO 178	38.1 Mpa	46.4 Mpa
Arrow at maximum force	UNE-EN ISO 178	2.5 mm	5.1 mm
Indentation Resistance - Brinell Hardness	UNE-EN 1534	179.95 HB (N/mm ²)	
Water absorption (24 h. in water at 20°C ± 2°C)	UNE-EN 317	0.59%	0.38%
Water absorption (48 h. in water at 20°C ± 2°C)	UNE-EN 317	0.5%	0.39%
Water absorption (4 days in water at 20°C ± 2°C)	UNE-EN 317	0.59%	0.43%
Water absorption (7 days in water at 20°C ± 2°C)	UNE-EN 317	1.09%	0.67%
Water absorption (14 days in water at 20°C ± 2°C)	UNE-EN 317	1.08%	0.71%
Water absorption (28 days in water at 20°C ± 2°C)	UNE-EN 317	1.663%	0.95%
Resistance to humidity under cyclical conditions - Var. Flex Resistance (%)	UNE-EN 321	-2.7%	-1.34%
Moisture Resistance - 5 hour boiling test - Var. Mass (%)	UNE-EN 15534-1	1.73%	1.28%
Resistance to salt spray - Variation ΔE	UNE-EN ISO 9227	1.25 ΔE	1.25 ΔE
Determination of thermal shrinkage	UNE-EN 479	0.236%	0.215%
SRI (LEED colours)	ASTM E1980-11	> 80	
Temperature Vicat	UNE-EN ISO 306	87.4°C	
Density	UNE-EN ISO 1183-1	1.54 g/cm ³	1.44 g/cm ³
Impact resistance	UNE-EN ISO 477	>7J	>20J
Slip resistance (brushed finish)	UNE-ENV 12633	Class 3	
Determination of bending temperature under load	ISO 75-2 :2005	82.7±0.7°C	84.7±0.9°C
Thermodynamic properties by sample DMA - natural loads.	ASTM E1640	T _g =93.19°C	
Classification of Reaction to fire	UNE-EN 13501-1:2007	Bfl s1	
External fire performance classes for roofs and roof coverings UNE EN 13.501 - 5:07/AC09	UNE-ENV 1187:2003 TEST 1	Broof (t1)	
Resistance to basidiomycete fungi	UNE-ENV 12038	Non-attackable	
Resistance to soft rot fungus	CEN/TS 15083-2	Non-attackable	

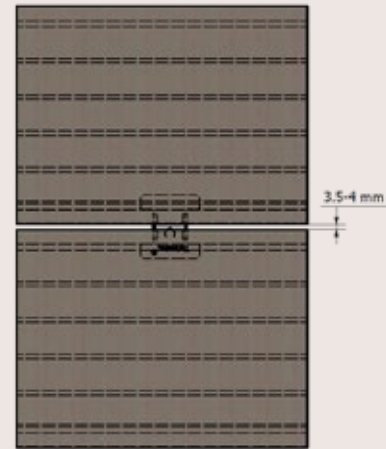

Available colours CHROMATIC TECNO - NATURE

Wengué	Miel	Moka	Marrón	Gris
2204	2213	2241	2212	2214

Available colours WOOD NATURE - WOOD NATURE MACIZA

Nogal	Teka	Silver	Castaño	Greenwood	Roble	Ipe
2321	2326	2332	2333	2350	2349	2348
Polar	Sándalo	Luna	Cinnamon	Cozumel	Nielsen	Habanna
2347	2361	2364	2365	2377	2481	2482

Available colours ETHNIC - SURCO

Lino	Antique	Bamboo	Iroko	Formentera	Indigo	Preto
2398	2397	2396	2395	2489	2490	2301
Aloha	Macao	Coffe	Koala	Blanco Ivory		
2508	2520	2522	2523	2217		

Accessories

TARIMATEC® H JOINT CLIP

	Value	Tolerance
Weight	22.50 g/ud.	± 0.5 g
Unit	200/1000	± 5 units
Materials	Stainless steel AISI 304 A2	
	*Stainless steel. AISI - 316L	

*On request.
Performance: 25 clips / m²

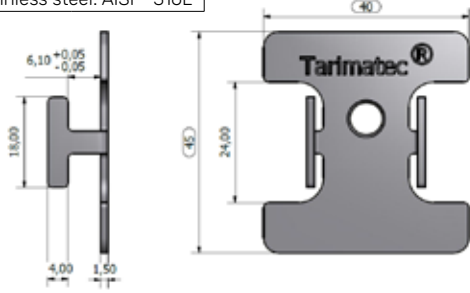

SCREW S3 A2 BIMET D12 5.5 X 30 mm

Performance: 7 screws / 3 m cover

	Value	Tolerance
Units Box	DEPENDING ON ORDER	
Materials	Body - Stainless Steel. AISI - 304L	
	Tip - steel	



TAPPING SCREW

Tapping screw INOX A2 - 6 x 60 mm
Tapping screw INOX A2 - 8 x 100 mm
Plug: Polyamide 6.6
Imprint 6X60 mm: PZZ
Imprint 8X100 mm: PZZ



	Value	Tolerance
Units	DEPENDING ON ORDER	
Materials	Body - Stainless Steel. AISI - 304L	
	Plug: PA 6.6	

TARIMATEC® ALUMINIUM STRIP

- Strip A (30x50x3.000 mm)
- 20 units/box

Strip suitable for indoor and outdoor use.

Chemical composition: EN AW 6005 T6 Alloy
Alloy chemical composition Standard S/EN 573-3

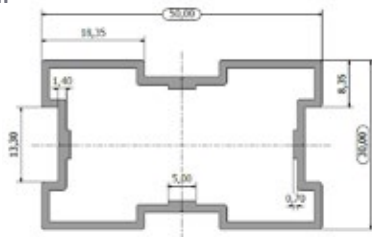

Si	Fe	Cu	Mn	Mg	Cr	Zn	Ti
0.50-0.90	0.35	0.50	0.50	0.40-0.70	0.30	0.20	0.10

Mechanical Characteristics: the UNE-EN 755-2:2009 Standard is applied, EN AW 6005 for Treatment State T6 and thickness of measurements in mm < 5: Tensile strength (Rm) 255 Mpa / Elastic Limit (Rp0, 2) 215 MPa / Elongation (A) 8 % / Applicable dimensional tolerances according to UNE-EN 755-9:200

SCREW DIN 7504 P A2 H 4.2 X 25 mm

	Value	Tolerance
Units Box	200/1000	± 5 units.
Materials	Stainless steel AISI 304 A2	
	*Stainless steel. AISI - 316L	



*On request.
Performance: 25 clips / m²

ALUMINIUM BRACKET 40 X 40 mm

Angle Bracket Joint Element
Strip A
(30 x 50 mm)
Aluminium
Packs of 10 units.
Fastening with screws
DIN 7504 P A2 H 4.2 X 22 mm

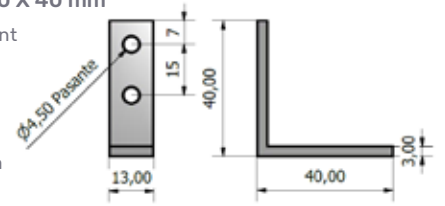

INITIAL PROFILE

Length: 2,000 mm
Alloy EN AW 6005 for Treatment
Condition T6
Fastening with screws
DIN 7504 P A2 H 4.2 X 22 mm

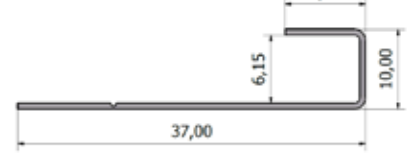

INITIAL CLIP

	Value	Tolerance
Weight	16 g/units	± 0.5 g
Unit	DEPENDING ON ORDER	
Materials	Stainless steel AISI 304 A2	
	*Stainless steel. AISI - 316L	

*On request.

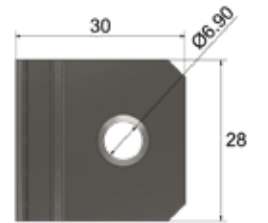

CONNECTING PLATE

Straight Connecting Element
Batten A
(30 x 50 mm)
Aluminium
Packs of 10 units.
Fastening with screws
DIN 7504 P A2 H 4.2 X 22 mm

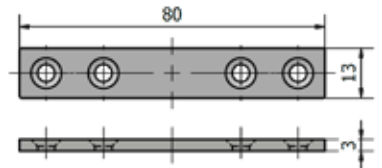

END PROFILE

	Value	Tolerance
Weight	2,600 g/m.	± 100 g/m
Width	180 mm	± 5 mm
Height	10 mm	± 0.5 mm
Length	3,000 mm	± 10 mm

Available colours

Wengué	Miel	Moka	Marrón	Gris
2204	2213	2241	2212	2214

Nogal	Teka	Silver	Castano	Greenwood	Roble	Ipe
2321	2326	2332	2333	2350	2349	2348
Polar	Sándalo	Luna	Cinnamon	Cozumel	Nielsen	Habanna
2347	2361	2364	2365	2377	2481	2482

Lino	Antique	Bamboo	Iroko	Formentera	Indigo	Preto
2398	2397	2396	2395	2489	2490	2301
Aloha	Macao	Coffe	Koala	Blanco Ivory		
2508	2520	2522	2523	2217		



There may be slight variations in the colour and surface finish, giving the decking a more natural finish. After a few months of exposure to the elements, as with wood, the colours lighten slightly, making the colour more uniform and stable

Composition

Tarimatec's raw material is ECO Fiber STONE, composed of PVC, rice husk and crushed marble. This makes a product that combines the best properties of both materials, guaranteeing a long life cycle, with no need for maintenance.

Environmental Information

Unlike other brands, the vegetable fibres used in the manufacture of the Tarimatec® cover do not come from the felling of trees, but are obtained from the reuse of by-products from the cultivation of cereals. It is totally recyclable.

CLEANING



Project
Cel Ras
Photograph
Paula Martínez

CLEANING INSTRUCTIONS

CLEANING INSTRUCTIONS

Although Tarimatec® does not require maintenance, it is recommended to clean the installation periodically to keep it looking good.

The space between the slats must be kept clear of organic debris to ensure good water drainage and proper ventilation.

Tarimatec® does not require any special treatment for its preservation, but the application of the Finish coating is possible.



If the Finish coating is used, only the cleaning method referred to this finish must be applied, as the use of other cleaning methods may affect the surface finish.

WATER STAINS

Appearance: Water stains can be caused by splashing water from swimming pools, irrigation, gutter discharge, roofs, etc., or even by the morning dew itself. This can produce puddles of water that, when evaporated, leave a visible ring formed by the substances dissolved in the water and even the juices that may be extracted from the plant fibres of the flooring itself. These stains are normal in this type of material and are not a deficiency of Tarimatec®, and do not affect the quality of the profile.

Cleaning: Cleaning this type of stain is very simple. Rub with a slightly dampened broom over the footprint so that the surface is soaked but not flooded. Leave to dry.

If any of the stains persist, repeat the operation by pouring soapy wood cleaner into a bucket with a small amount of water. Dip the broom in it and rub the surface with it until it foams. Remove the standing water with a broom to avoid puddles.

For stubborn lime scale stains, use a vinegar cleaner or an anti-lime scale cleaner, applying it directly to the slat previously dampened with water. Then rub and rinse with water. Do not allow the water to soak in. A Scotch type scouring pad can be used to facilitate removal, as lime scale is a deposit/incrustation.

STAINS FROM SOFT DRINKS, WINE, COFFEE

Stains from soft drinks, wine or coffee can be removed with a soapy wood cleaner. If any of these stains persist, apply a splash of bleach to a wet floorboard and rub with a broom or brush. Leave for a maximum of 20 minutes and rinse with plenty of water.

STAINS FROM GREASE, SUN CREAM, OIL, FOOD, ETC.

Clean the stain as soon as possible. First remove the oil, cream or surface grease with absorbent paper or cloth. Once the stain can no longer be removed, apply Tarimatec degreasing cleaner to the stain, following the instructions for use:

- Carry out the cleaning by sufficiently ventilating the area.
- Follow product safety instructions.
- Remove excess oil with absorbent paper.
- Apply Tarimatec degreasing cleaner to the stain and rub with a broom or cloth in all directions, making sure that the product has penetrated the area. Repeat 2 times.
- Leave to act for 15 minutes. After this time, rinse with plenty of water.
- Pour a few drops of Fairy dish washing soap on the area where the stain was, and rub with a clean broom or brush in all directions (if using the same one as the one used to spread the degreaser, it must have been thoroughly rinsed beforehand), so that the stained area is covered with foam.
- Leave for 15 minutes and rinse with plenty of water. Remove any puddles of water. Leave to dry.

Alternatively, for occasional stains, you can use a dry cleaner such as **Cebrañín** Stain Remover, following the instructions for use.



For both Tarimatec® degreasing cleaner and dry stain remover to be effective, the surface of the floor must be completely dry at the time of application. If this is not the case, the cleaning will not be effective.

TREE RESIN STAINS

For tree resin stains, clean using a cloth dampened with ethyl alcohol. Do not apply ethyl alcohol directly and leave it to act, as it may stain the decking.

RUST STAINS

For rust stains, apply "Ferrokit" or another rust cleaner on the stain. Leave to dilute the stain and rinse. Diluted hydrochloric acid can also be used if the stain persists.

STAINS OF DECOMPOSING ORGANIC MATTER

Wet the floor with water, then pour bleach over the area to be cleaned and spread it with a brush or broom. Leave for 15 minutes and rinse with plenty of water.

SNOW

To remove snow, you can use coarse salt and let it melt. If you shovel snow, use a shovel with a rubber-protected tip or similar to avoid damaging the decking.

CHEWING GUM STAINS

If the chewing gum is soft and very sticky, harden it by applying ice. Once hardened, mechanically remove the main board by prying it off, taking care not to damage the decking. If any residues are still adhering, remove with a cutter, scraping with the tip of the blade in the direction of the brushing until the residues are removed. Rub with a fibre pad, if necessary, to finish removing the stain and/or residue.

DIFFICULT STAINS OR STAINS OF UNKNOWN NATURE

For stubborn stains of unknown nature, follow different cleaning steps:

- Water
- Soapy cleaner
- Diluted bleach (subsequent rinsing with water)
- Concentrated bleach. Maximum action time, 15 minutes. (rinse with water afterwards).
- Diluted ammonia. Maximum action time, 15 minutes. (rinse with water afterwards).
- Diluted hydrochloric acid. Maximum action time, 10 minutes. (rinse immediately afterwards with plenty of water).
- Concentrated hydrochloric acid. Maximum action time, 10 minutes. (rinse immediately afterwards with plenty of water).



In all cases, prior to these cleaning tests, the floor must always be wet. Failure to be so could result in damage to the surface.

BURNS OR SUPERFICIAL DAMAGE TO THE DECKING

For alterations or damage (burns, discolouration due to external agents) to the surface of the decking, clean with a scotch or metal brush (bristle type, toothbrush type). In case of small incrustations, you can use the scotch or a cutter, in the direction of brushing or longitudinal direction of the decking.

REGULAR CLEANING

For any stain, act as quickly as possible to prevent it from being absorbed into the surface.

Even if your Tarimatec® installation does not look bad and does not require any maintenance, it is advisable to carry out a general cleaning every 3 to 6 months, depending on use and installation area. This will make your decking look better.

To do this, carry out a cleaning following the steps below:

- Use pressure washer (max. 180 bar) (**see instructions for use of pressure washer below**)
- In a bucket with a small amount of water, pour a splash of soapy cleaner and bleach, and with a clean broom, rub vigorously in different directions until foam is created. Leave to act for a few minutes and rinse with plenty of water, avoiding puddles. Leave to dry.

Depending on the size of the installation, this cleaning should be done in one go or in zones several times.

Except for the soapy cleaner, always carry out a test cleaning in an inconspicuous place on the floorboard to observe the results. Strictly follow the cleaning instructions. The use of other cleaning products or improper use is the sole responsibility of the customer.



Tarimatec® is not resistant to acetone, solvents, strong acids other than those recommended here, silicones or paints. In the same way, any cleaning product applied for an excessive period of time may cause irreversible marks and surface damage.

CLEANING WITH A PRESSURE WASHER

A pressure washer with a maximum pressure of 180 bar can be used for deep cleaning of the decking. The cleaning should be carried out with a fan jet and should cover at least the width of half a plank.



In order to avoid the appearance of "little paths" and surface marks, it is essential to apply the jet in the direction of brushing, avoiding the "forward-backward" rocking movement, and with a uniform speed in the displacement of the jet.

This will be done, board by board, under the same application conditions if we want to obtain a uniform and effective cleaning. This type of cleaning is recommended on an occasional basis, when you want to remove encrusted dirt that is not removed by periodic cleaning.

IF YOUR INSTALLATION HAS THE FINISH COATING

You should only clean your installation with **water and a soapy cleaner**, and bleach may be used if any stains are stubborn. With this finish you should not need to use any other products.



Do not use a pressure washer if your installation has this finish, as it can significantly reduce its durability and effectiveness against stains.

You can prolong the life of your finish by mopping and bucket cleaning your installation with a 1:10 dilution of Finish in water. The installation must be perfectly clean before this operation, otherwise any stains that may be present will not be removed for several months.

In public facilities (hotels, restaurants, etc.) it is recommended to apply a coat of Finish once a year or as soon as it is observed that the cleaning of stains is not as effective. This application should be carried out by a professional applicator. Please refer to the information about Finish collected in this technical manual.

Tarimatec® products, although they are open-pored, have a very effective cleaning protocol due to a formulation that is highly resistant to virtually all cleaning products.

The effectiveness of cleaning is based more on the contact time of the various cleaning products than on the energy used in scrubbing.



INSTALLATION

VERTICAL SYSTEM - MONT BLANC



Assembly instructions

These assembly instructions are designed so that the installation of the "Vertical System" is carried out correctly, so that you can enjoy your product with all the guarantees of durability and good performance.

Please read the instructions before installation.

Condition of substrate / support

The "Vertical System" is a ventilated façade system, which is installed on battens. These battens are mechanically fixed to the substrate, support or wall, therefore this installation base must support the installation of fastening screws of the structure.











WARNING

The condition of the installation substrate is vital for a good performance of the product, as well as to ensure the safety of the installation. Tarimatec is not responsible for the state of the substrate of each installation. This section, as well as the quantity and type of fixings to be used, will be determined by the technical management of each project, the one offered here being a standard solution as a decorative profile and not as a ventilated façade. Each ventilated façade installation requires a specific study in this respect.

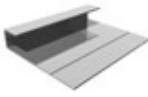
Assembly elements

For the assembly of the "Vertical System" using the Mont Blanc profile, the necessary mounting elements are as follows:

<p>Mont Blanc Profile</p> 	<p>Mont Blanc Batten</p> 	<p>Mont Blanc PA Clip</p> 	<p>Screw 7505A 2.5x30 mm</p> 
<p>Initial profile</p> 	<p>Screw 7504P 4.2x25 mm</p> 	<p>Screw cap</p> 	<p>Screw-plug</p> 

Installation

Battening

As mentioned in the previous section, the substrate where the Vertical System is to be installed must be stable to allow and guarantee the fastening of the screws. The surface must be level, since the battens are placed directly on it.



If the mounting surface is not level, wedges or levelling brackets can be used. These elements must be suitable for outdoor use and the installer must ensure their suitability.



The installation battens are fixed to the substrate by means of a tapping screw-plug of at least 6 mm. These screws must be made of AISI 304 stainless steel, and AISI 316 if the installation is to be carried out in marine environments.

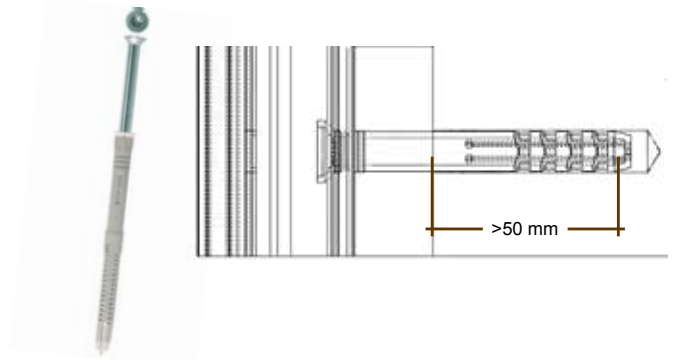

The tapping screw-plug must enter at least 50 mm into the substrate, so that when the plug expands, correct fastening can be guaranteed. The maximum spacing of the screws fastening the batten to the wall shall be a maximum of 750 mm.

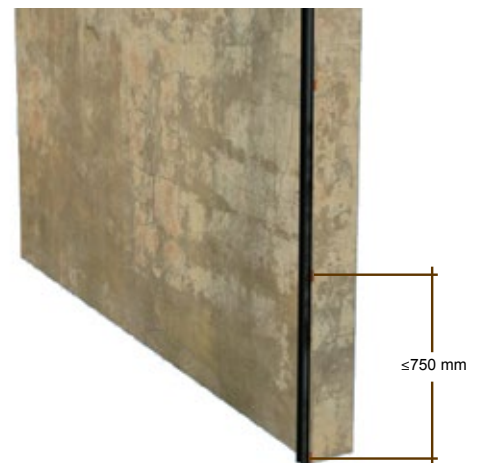

As can be seen in the picture above, a 3 m long strip should be fixed at least 5 equidistant points.

Once this point has been clarified, the maximum separation distance between battens is discussed. At this point, it is worth highlighting the presence of the double battens at the ends of the installation, where all the end pieces of the Mont Blanc profile coincide, this being one of the critical points of the installation.



WARNING The correct levelling of the battens must be ensured in order to guarantee, especially outdoors, the good behaviour of the profiles in the expansions and contractions produced by temperature variations. Incorrect levelling of the battens can hinder the natural movement of the pieces and consequently cause them to arch.

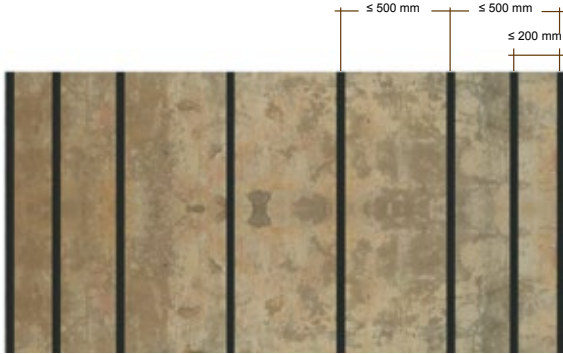

As can be seen in the previous image, the separation between battens shall not exceed 500 mm. At the ends, between the first and second battens, an intermediate batten shall be placed at a distance of no more than 200 mm from the first batten.

In the upper part of the installation, we will place horizontal battens. These will make it easier to lay the final finish once the Mont Blanc profile has been installed. In the same way, the creation of "panels" in the form of a closed structure can considerably facilitate the levelling of the battens with each other.



These horizontal battens can be screwed to the same substrate and in the same way as the vertical battens, thus being perfectly fastened and being able to place the appropriate finishing profile on it with total guarantee.

Placement of profiles

Once we have the battens in place, we can begin installing the Mont Blanc profile, although first we will need some element or profile to hold the first Mont Blanc profile slat. This element is the starting profile, which will provide good fastening of the slat, with this fastening being completely hidden.

The initial profile can be fixed to the batten strip with the screw 7504P A2 4.2 x 25 mm as shown in the picture. The profile shall be positioned 15 mm from the lower end of the batten.

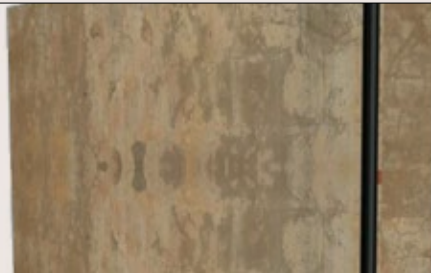

Once the initial profile is in place, the first slat of Mont Blanc profile can be fitted, which will be perfectly secured on the underside.



The upper part of the board is fastened with the Mont Blanc fastening clip. This clip is inserted into the channel of the strip with a simple twist and we fit it into the clamping flange of the Mont Blanc profile until we hear a "click". Although the clip is provided with a hole for a screw, it is not necessary to screw it in for the time being, which considerably reduces the assembly time.





As shown in the previous pictures, we place a clip for each of the installed battens, which will hold the upper part of the first row of Mont Blanc profile and the lower part of the second row.

In the second row of the installed Mont Blanc profile, you can see that there are two boards. These two boards share the same clip, with a gap of **6 mm** between them for boards up to **3 m** long.



If during the laying of the boards, we have to rectify the position of any of them, we will not do it by hitting directly on the profile slat, but we will place a wooden block at the end of the profile and we will hit with the nylon mallet on the block until we get the position we are looking for, as shown in the following image.

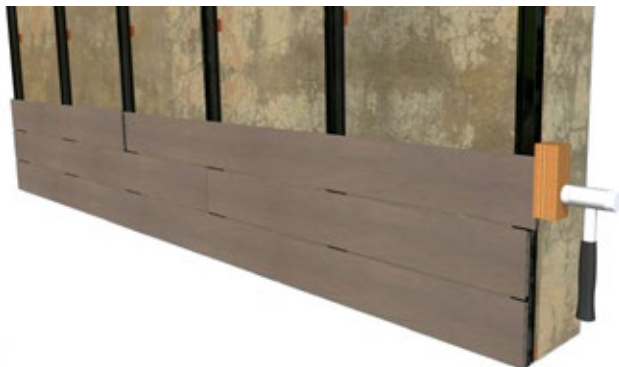

WARNING
Failure to respect the expansion joint between profile heads can lead to a collision between boards in the natural process of thermal expansion, and consequently to possible warping of the boards.

The 6 mm joint between boards must be centred with the vertical of the clip hole. This is to ensure that the heads of each of the boards are perfectly anchored by the clip without the risk of them losing their grip due to the normal expansion and contraction that the profile may undergo as a result of the temperature.



In addition to taking special care to centre the joints, as a precaution, we will fix each of the boards as centrally as possible. In the image below, we mark the area where we would fix these three boards.



To carry out this operation we use the 7505A 2.5x18 mm screw. We place it in the housing provided in the clip, and screw it to the board as shown in the following images.

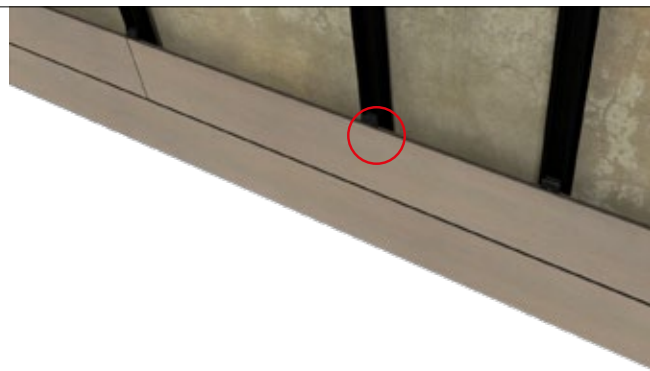

This simple system allows for the expansion and contraction of the piece, but prevents the piece from moving laterally due to these expansions and contractions, which, in addition to changing the visual appearance of the façade, may cause some of the end pieces to lose contact with the clip.

Once screwed in, the screw prevents the profile from sliding sideways and is completely hidden.

As mentioned above, it must be emphasised that this fastening must be carried out in the most centred clip possible with respect to the profile, and on all the profiles of the installation, regardless of their length.

Each Mont Blanc profile must rest on at least 3 battens, so this will determine the minimum length of each profile.

Once the lateral fixing of the boards has been completed, we continue placing the rows of boards following the relevant indications that we have already referred to in this manual, and once we have completed 5 rows of Mont Blanc profile in our installation, we will screw the following mounting clips to the strip, as shown in the following pictures





The screw used is DIN 7504 P A2 4.2 x 25 mm, and each of the clips is screwed onto the fifth row of the Mont Blanc profile. It is only necessary to screw the clips to the strip every 5 rows of installed profile. e.g. in an installation with 23 rows of Mont Blanc profile, it is only necessary to fix the clip to the strip in 4 rows (rows 5, 10, 5 and 20).



Once the last profiles of the installation have been cut lengthwise, it will look as shown in the following image.



WARNING
The tightening torque of the screw must be the minimum torque that allows screwing into the aluminium profile, so that the expansion and contraction of the profile is not hindered.



The last row of the cut Mont Blanc profile is attached to the bottom of the strip using the Mont Blanc clip. The upper part of the profile (which is the cut part) can be fixed using the starting profile. To do this, cut the starting profile into 40 mm pieces, and cut as many pieces as there are vertical battens in the installation.

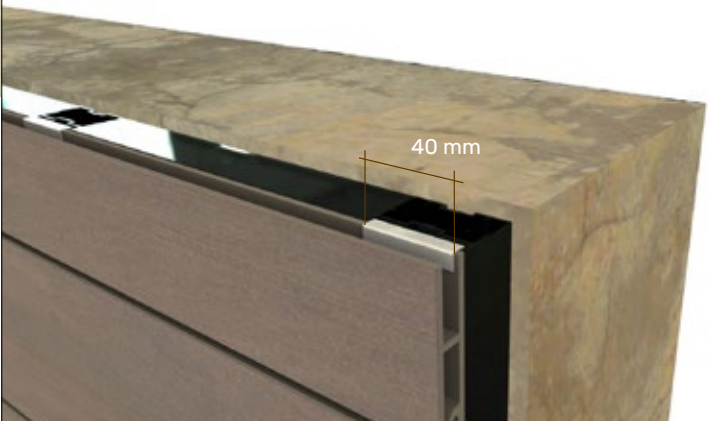

We continue laying Mont Blanc profiles in the desired lengths to complete the remaining rows until the end of our installation. Normally it will not be the case that a complete plank will coincide with the end of our installation, so we will have to cut the Mont Blanc profiles of the last row lengthwise.

The cut starting profile is inserted at its longest part into the guide of the vertical strip, also taking the fin of the Mont Blanc profile if we complete the installation with a complete profile, or with the wall of the lower part, if we have to cut the piece lengthwise, as in the previous example. In the following image we can see the installation of the profile in more detail.

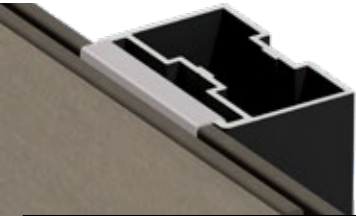

Completion of the installation

To complete the installation, place the end cap profile on the top and sides. It is essential to follow the instructions below to ensure that the finishing profile performs well.

The termination profile is a solid profile with a cross-section of 179 x 10 mm. This profile is very versatile and adaptable to different configurations or situations of installation completion that may arise.

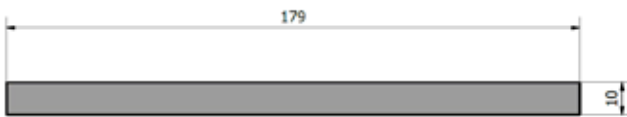

The end profile or cover plate is screwed directly onto the perimeter battens of our installation, which justifies the horizontal battens placed at the top of the assembly.

To fix this profile, we use the cover screw. For to use this screw, a pre-drilled hole must be drilled in the cover. 10 mm in diameter. The maximum spacing between bolts shall be 500 mm.

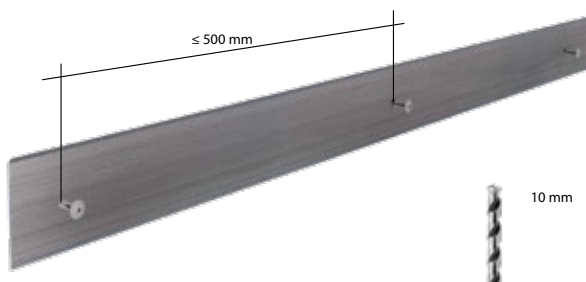

It can be finished with a cover, which will be as shown in the image. To avoid the closure of the expansion joint, in the perimeter pieces, the screw 7505A that is placed in each profile to avoid the displacement of the boards, can be placed in the outermost clip as shown in the image. The expansion joint shall be at least 5 mm.

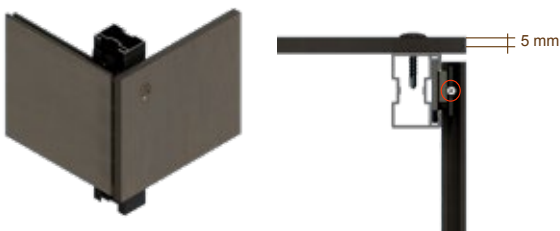

It is also possible to make the mitred joint with a Mont Blanc profile on both sides. In the same way, the fixing of the perimeter profiles with the screw 7505A, will be done on the outermost clip. The expansion joint between the mitre joints must also be at least 5 mm.

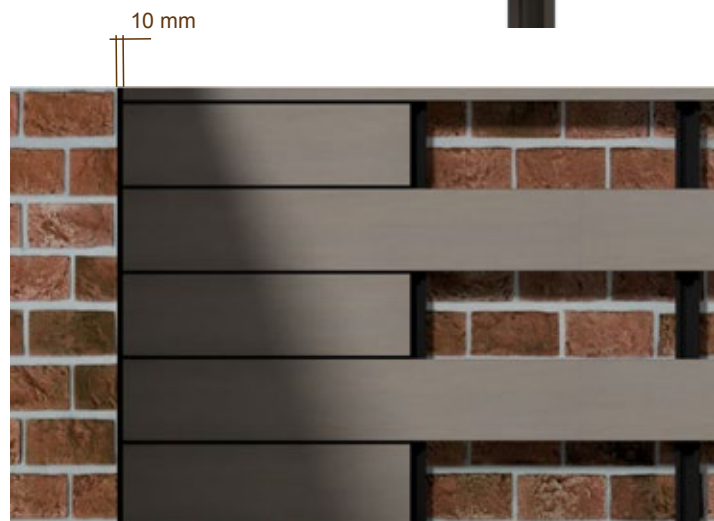
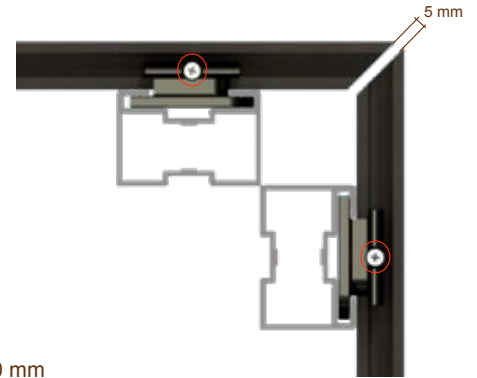

The separation of the joint between the top of the Mont Blanc profile and the wall, shall be at least 10 mm.



WARNING

In installations where the orientation of the Mont Blanc profile is horizontal, we recommend the purchase of slats with a Finish finish to reduce the visibility of water spots.

VERTICAL SYSTEM MONT BLANC

Façade profile



MONT BLANC PROFILE Dimensions

	Value	Tolerance
Weight	1,600 g/mL	± 65 g/m
Width	150 mm	± 0.5 mm
Height	15 mm	± 0.5 mm
Length	3,000 mm	± 10 mm

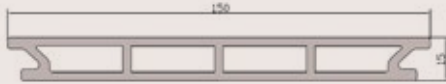

For calculation estimate 6.5 mL / m².
Customised lengths possible, from 100 m², maximum length 4,000 mm.

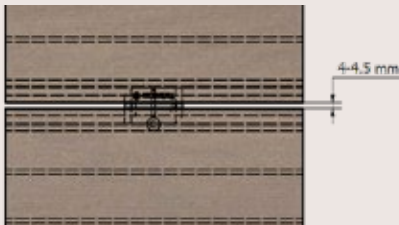

PHYSICAL AND MECHANICAL PROPERTIES	MET. TEST	VALUE
Coefficient of linear expansion	UNE 53126	2.84·10 ⁻⁵
Modulus of elasticity	UNE-EN ISO 178	4,675 Mpa
Resistance to bending	UNE-EN ISO 178	29.4 Mpa
Arrow at maximum force	UNE-EN ISO 178	2.9 mm
Shore hardness	UNE-EN ISO 868	65
Water absorption (24 h. in water at 23 °C)	UNE-EN ISO 62	0.99%
Water absorption (7 days in water at 23 °C)	UNE-EN ISO 62	3.78%
Temperature Vicat	UNE-EN ISO 306	87.4%
Density	UNE-EN ISO 1183-1	1.54 g/cm ³
Impact resistance	UNE-EN ISO 477	>5J
Determination of bending temperature under load	ISO 75-2 :2005	80.3±0.7°C
Classification of Reaction to fire	UNE-EN 13501-1 :2007	B-s3, d0
Wind pressure and suction	ETAG 034	>5000 P

There may be slight variations in the colour and surface finish, giving the decking a more natural finish. After a few months of exposure to the elements, as with wood, the colours lighten slightly, making the colour more uniform and stable

Composition

Tarimatec's raw material is ECO Fiber STONE, composed of PVC, rice husk and crushed marble. This makes a product that combines the best properties of both materials, guaranteeing a long life cycle, with no need for maintenance.

Environmental Information

Unlike other brands, the vegetable fibres used in the manufacture of the Tarimatec® cover do not come from the felling of trees, but are obtained from the reuse of by-products from the cultivation of cereals. It is totally recyclable.

Façade profile

MONT BLANC JOINING CLIP

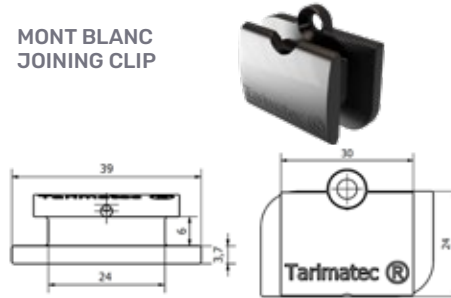

Made of PA 6.6 - High UV resistance

PROPERTIES	MET. TEST	VALUE
Density	ISO 1183	1.14 g/cm ³
Melting point	DSC	222 °C
Mould shrinkage	-	1 - 1.4 %
Tensile strength	ISO 527	85 MPa
Modulus of elasticity	ISO 527	2.900 MPa
Tensile modulus at strain	ISO 527	4.5%
Tensile modulus at break	ISO 527	35%
Temperature Vicat	UNE-EN ISO 306	206 °C
Water absorption (24 h. water at 23 °C)	UNE-EN ISO 62	2%
Impact resistance - 23 °C	ISO 180/A	>5.5 KJ/m ²

MONT BLANC ALUMINIUM STRIP

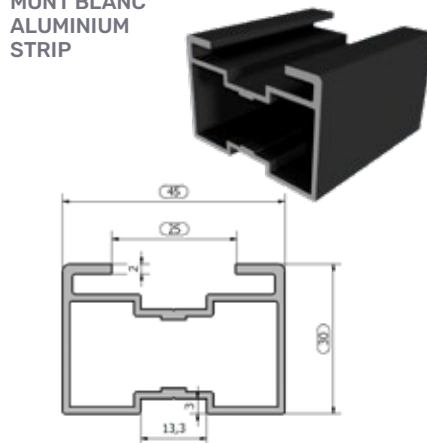

	Value	Tolerance
Weight	777 g/mL	± 50 g/m
Units / Box	20	-
Length	3,000 mm	± 10 mm

	Si	Fe	Cu	Mn	Mg	Cr	Zn	Ti
	0.50-0.90	0.35	0.5	0.5	0.40-0.70	0.30	0.20	0.10

Chemical composition: EN AW 6005 T6 Alloy
Alloy chemical composition
Standard S/EN 573-3

Mechanical Characteristics

the UNE-EN 755 -2:2009 Standard is applied,
EN AW 6005 for Treatment State T6 and thickness of measurements in mm < 5: Tensile strength (Rm) 255 Mpa / Elastic Limit (Rp0, 2) 215 MPa / Elongation (A) 8 % / Applicable dimensional tolerances according to UNE-EN 755-9:200

FLAT ALUMINIUM STRIP 45x11 mm

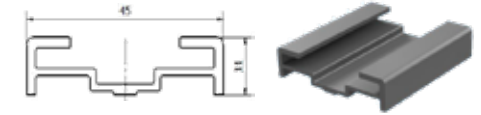

	Value	Tolerance
Weight	368 g/mL	± 15 g/m
Units / Box	20	-
Length	3,000 mm	± 10 mm

SCREW DIN 7504P A2 H 4,2X25 mm.



	Value	Tolerance
Units Box	200/1000	± 5 units.
Materials	Stainless steel. AISI - 304L *Stainless Steel. AISI - 316L	

*On request..

SCREW DIN 7505A A2 2.5 x 30 mm.



	Value	Tolerance
Units Box	200	± 5 units.
Materials	Zinc plating *Stainless Steel. AISI - 304	

*On request..

INITIAL PROFILE

	Value	Tolerance
Length	2,000	± 1 mm
Materials	Aluminium - Alloy EN AW 6005 Treated. T6	
Fixing	Screw DIN 7504P A2 H 4.2X25 mm	

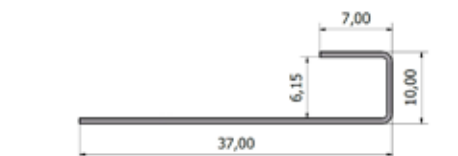

COVER



	Value	Tolerance
Weight	2,600 g/mL	± 100 g/m
Width	180 mm	± 5 mm
Height	10 mm	± 0.5 mm
Length	3,000 mm	± 10 mm

Available colours

Wengué	Miel	Moka	Marrón	Gris
2204	2213	2241	2212	2214

Nogal	Teka	Silver	Castaña	Greenwood	Roble	Ipe
2321	2326	2332	2333	2350	2349	2348
Polar	Sándalo	Luna	Cinnamon	Cozumel	Nielsen	Habanna
2347	2361	2364	2365	2377	2481	2482

INSTALLATION

VERT. VERTICAL - ANNAPURNA



Assembly instructions

These assembly instructions are designed for the correct installation of the ANNAPURNA decorative profile, so that you can enjoy your product with all the guarantees of durability and good performance.

Please read the instructions before installation.

Edition 12 25-01-2025

Project
Daar Arquitectura
Photograph
Álvaro Viera

Substrate / support condition

The Annapurna profile is a decorative profile that can be used in a façade cladding system. The Annapurna, as a decorative profile, allows for multiple solutions, provided they guarantee the stability of the profile over time. The following installation example is carried out using a frame and aluminium angle profiles. This frame is mechanically attached to the substrate, support, or wall; therefore, this support or substrate must be capable of accommodating the installation of screws to secure the structure.



WARNING

The condition of the installation substrate is vital for a good performance of the product, as well as to ensure the safety of the installation. Tarimatec does not assume responsibility for the stability of the installation in any of its aspects; it is the responsibility of the installer and/or the project management to ensure this point.

The system consists of a frame made of 40x40 square tube lacquered in black. To hide the joints, a mitre cut is made at the corners.



Assembly elements

For the installation of the Annapurna profile, according to the example described here, the necessary mounting elements would be the following:

Annapurna profile (depending on size, to be chosen)

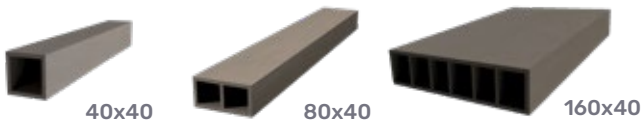

40x40x2 Profile
black lacquered

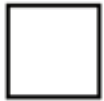

Angle 40x2
black lacquered



Substrate fastening
elements



Rivets



All these assembly elements, with the exception of the rivets, are supplied by Tarimatec®.

Installation

Battening

As mentioned in the previous section, the substrate where it is to be installed must be stable to allow and guarantee the fastening of the screws. The surface must be level, since the battens are placed directly on it.



The fixing of the frame shall be carried out with a fastening element and the method of fixing the frame shall be as follows, appropriate to the type of substrate to be installed. For stable substrates and good consistency, this fixing shall be carried out at different points, with a separation between fixing points of no more than 750 mm. As a fastening element, a socket bolt can be used that penetrate at least 50 mm into the substrate or wall to be installed.

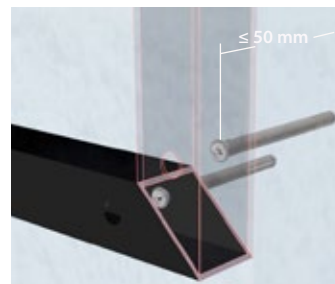

The profiles are positioned until the outer frame of the panel to be installed is made, fixing as indicated above.



Within the frame, and following the above-mentioned fixing spacing guidelines, horizontal clamping profiles are placed at a maximum distance of 700 mm from each other.

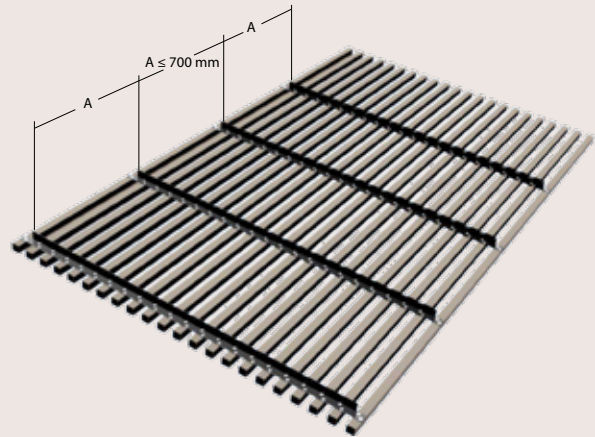
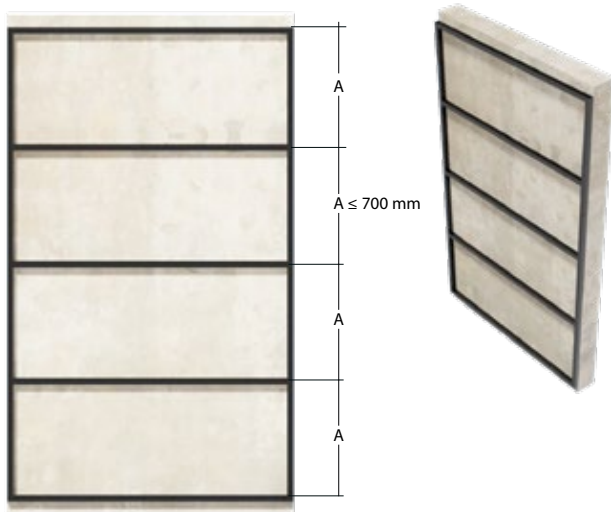

In the same way as for the panel, the spacing between angles must be the distance "A", the same as the spacing between horizontal profiles in the frame.



For a good performance of the Annapurna profiles, and to avoid undulations, it is essential that the aluminium profiles are correctly levelled and fixed to the substrate.

Laying of profiles

Once the frame is anchored to the wall, the Annapurna profiles are assembled to the 40 mm angle. At the ends of the angle, a fin width of 45 mm is cut to fit into the frame fixed to the wall previously made.

To carry out this fastening, two holes are drilled per profile in each corner with a diameter of 4.5 mm. The holes are drilled through the angle and through the face of the Annapurna profile that is touching the angle. These holes are then enlarged to a diameter of 8 mm in the angle only.

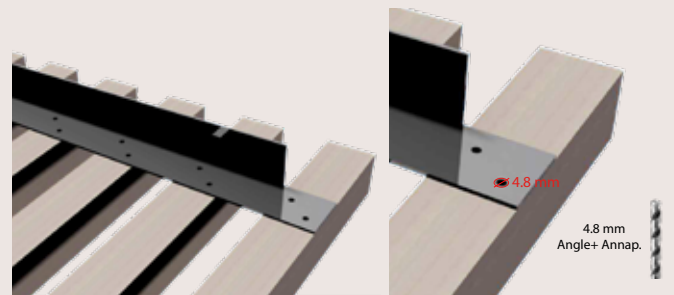

As above, a 4.8 x 16 mm rivet is used, but in this case a 10 mm diameter head will suffice.

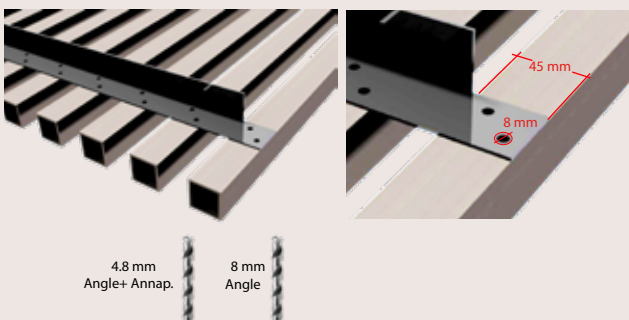
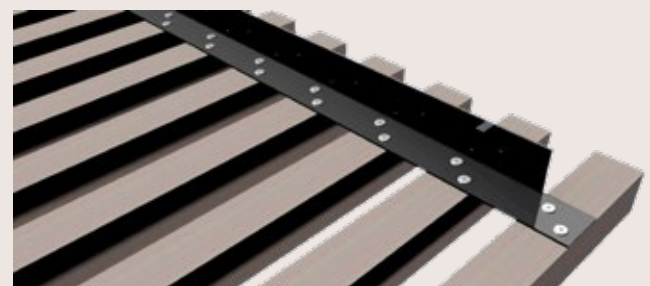

Once the holes have been drilled, the individual Annapurna profiles are attached to the angle using rivets. The rivets must be 4.8 x 16 mm long. The rivet head should have a minimum diameter of 14 mm. This is to facilitate possible expansion and contraction of the profile due to changes in temperature and humidity.

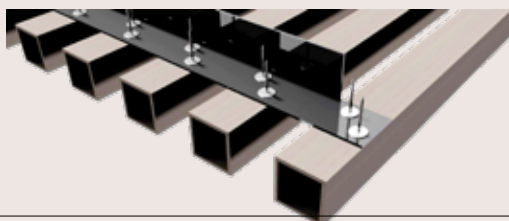

With this last angle in place, we now have the complete grill to be placed in the rectangular frame fixed on the frame and the horizontal profiles fixed to the wall.

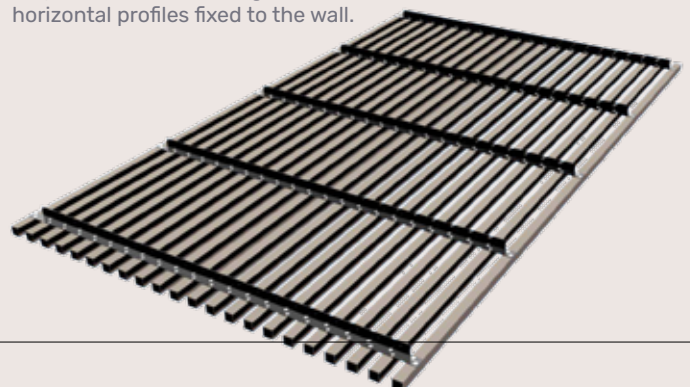

We lift the Annapurna profile block fixed with the angles, and "hang" it on the 40x40 mm profile frame fixed to the wall.



The flange of each of the angles fixed to the Annapurna profile rests on each of the 40x40 mm square tubes placed horizontally on the wall frame.



Once the Annapurna profile panel was hung, we riveted each of the 40 mm angle wings to the horizontal tubes of the wall frame.

The fins are fixed to the horizontal square tubes using 4.8 x 16 mm rivets. These should not be separated by more than 600 mm. The distance between the end of the profile and the ground must be at least 10 mm to avoid collisions due to expansion and contraction.

Once all the fixings and retouching, if necessary, have been carried out, our Annapurna decorative profile installation is complete.

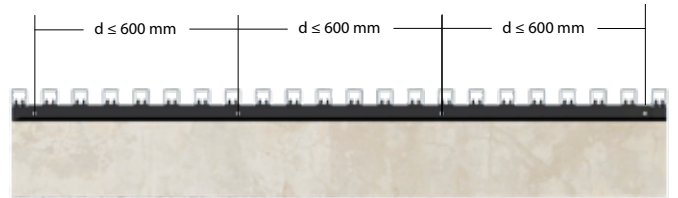

If installing on Annapurna 160x40 mm with edge fixation, an internal reinforcement profile must be used in the fixing cavity.

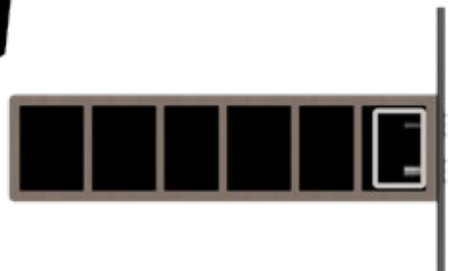

BASTION SYSTEM

The following section explains how to assemble a fence using the BASTION system. The basic assembly elements required are the following:



The profiles among which one can choose as a separator element for the fence are as follows:

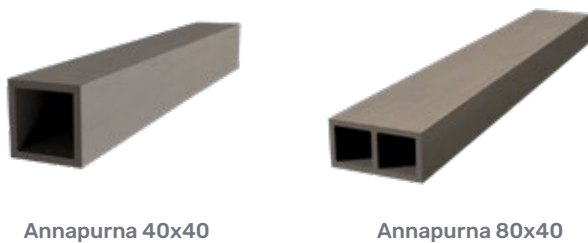

Assembly instructions

Below is an example of installing the BASTION system on a concrete parapet.

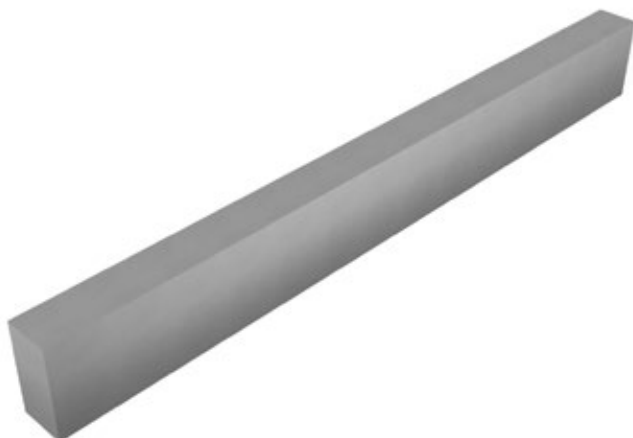

First, the posts are placed, which will be anchored with the appropriate mechanical fastening.



The project management team will decide, based on the type of material of the support, the appropriate mechanical anchoring that ensures the stability of the system.

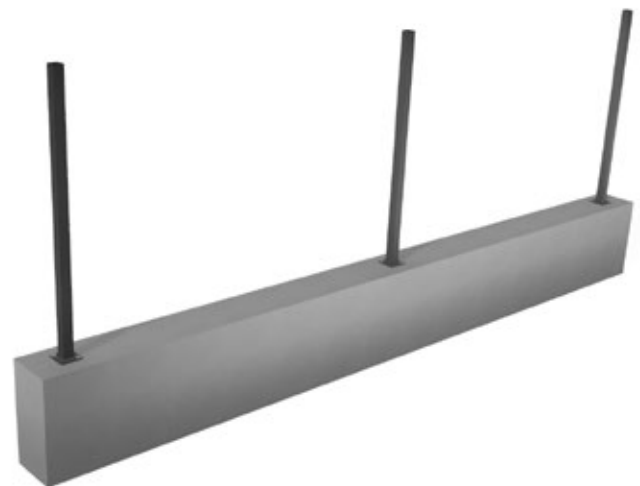
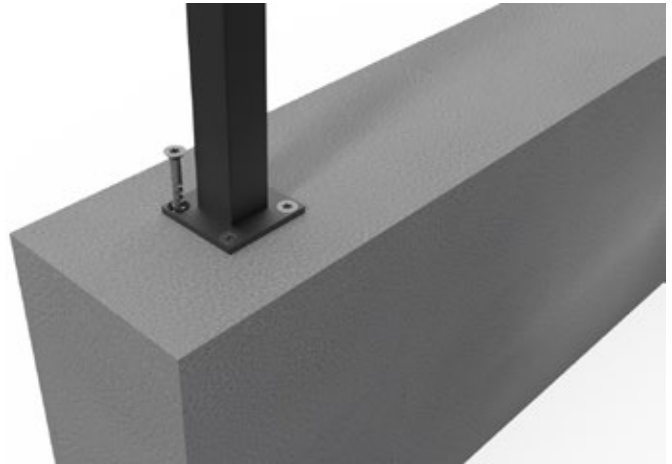

The centre-to-centre spacing between posts will be determined by the type of profile used in the fence. These will be:

- Separation "A" (Annapurna 40) = 1,000 mm
- Separation "A" (Annapurna 80) = 1,500 mm

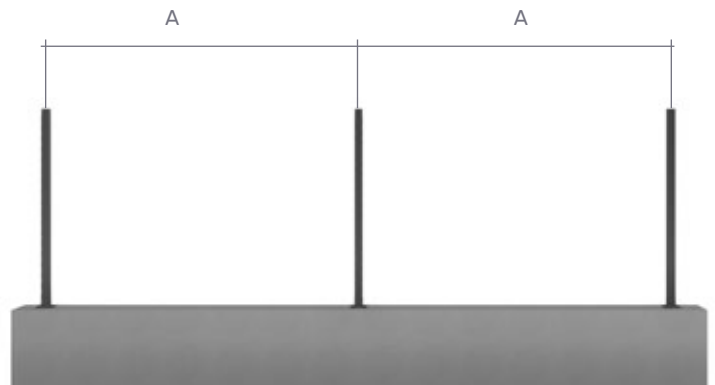

We sheath the posts with the Annapurna 80x80 mm, leaving them resting on the base of each post. The maximum height of these posts shall not exceed 2 meters.



We place the base aluminium profile on the sides of the Annapurna 80x80 profile, which will serve to place the Annapurna 40x40 or Annapurna 80x40 profiles that we will use to assemble the fence.



The aluminium side base profile is attached to the sides of the Annapurna 80x80 mm using the 7504B 4x40 mm screw. The distance between the fastening screws shall be a maximum of 400 mm. In the area where the screw is placed, a pilot hole should be drilled using a 3.5 mm bit that is approximately 50 mm in length. This drill will penetrate the aluminium side base profile, the 80x80 mm Annapurna, and the post.

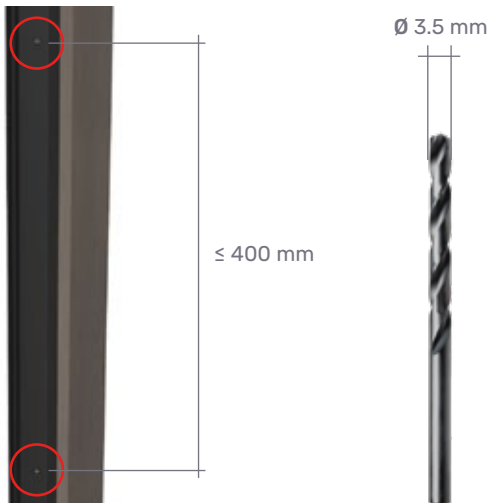

Once the side aluminium profiles are fixed, the aluminium caps are cut to the desired length at which the Annapurna fence profiles should be spaced apart.

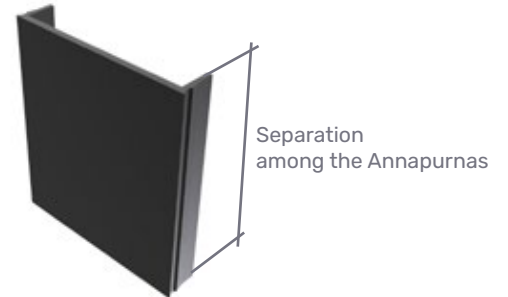

The cut lid is fitted into all the installed side base profiles. This is done by pressing, so it needs to be placed and then struck with a rubber mallet.

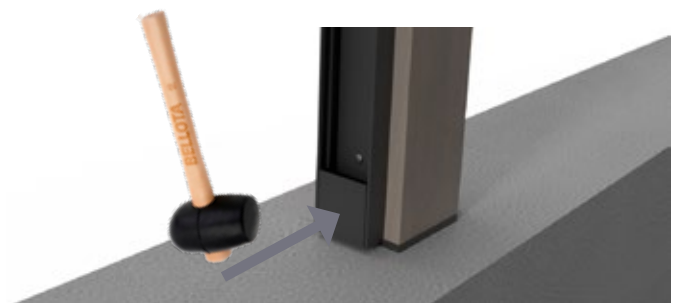

The first Annapurna profile is placed, in this case, 80x40.

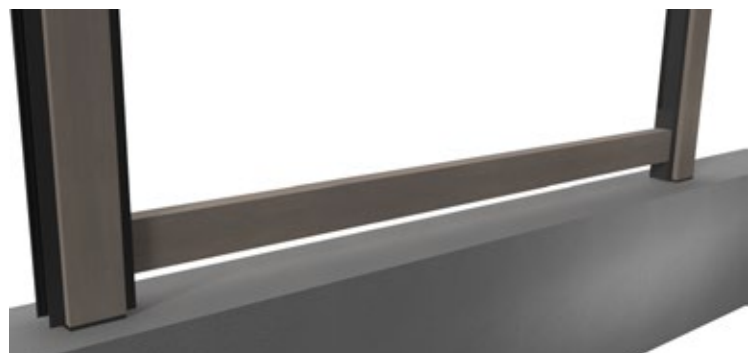

The length of the Annapurna should allow a margin of between 5 and 8 mm on each side.

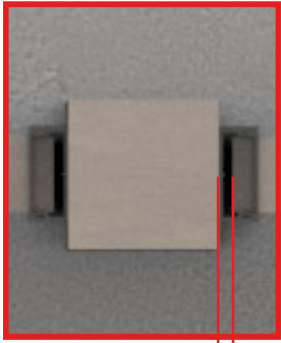

5-8 mm

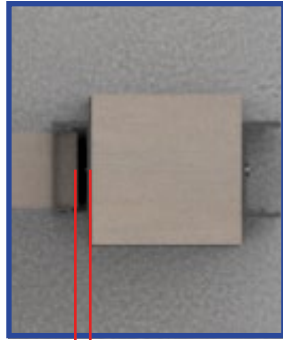

5-8 mm

The placement of each of the profiles is repeated until the fence is completed, following the previously shown instructions. Once the last Annapurna is placed, the distance between the Annapurna and the end of the lateral base profile is measured.

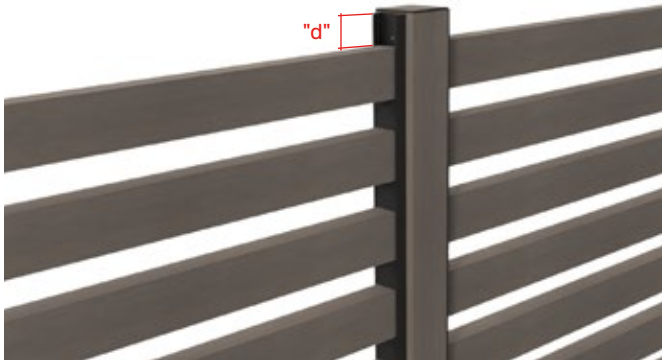

At that distance "d" is where the last aluminium cover will need to be cut, which will secure the entire system in place.

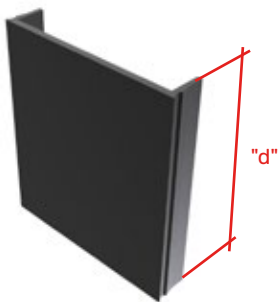

The aluminium caps of the last row are cut and fitted in the manner previously indicated.

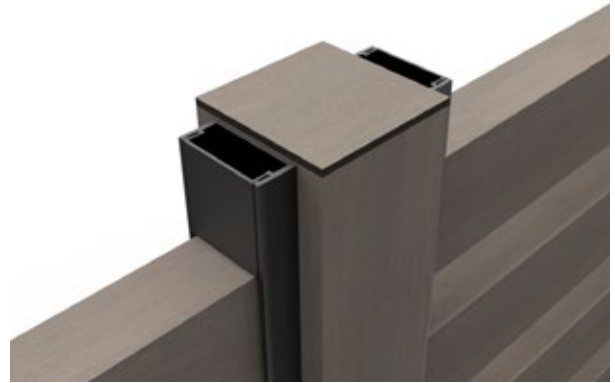

To conclude, end caps are placed on the ends of each aluminium profile.

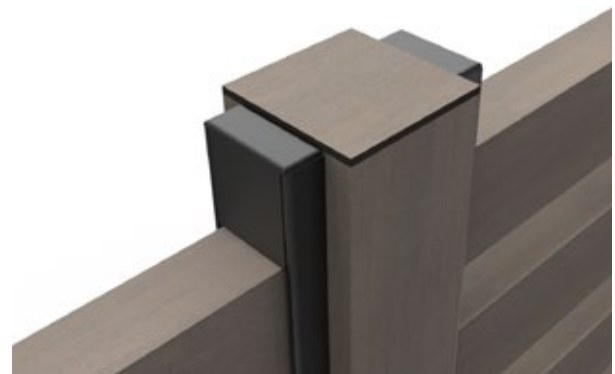

With this, the installation would be complete.



TECHNICAL INFORMATION

VERTICAL SYSTEM
ANNAPURNA

 **Tarimatec**

Annapurna

ANNAPURNA 40 X 40

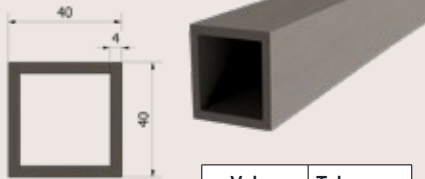

	Value	Tolerance
Weight	910 g/mL	± 50 g/m
Width	40 mm	± 0.5 mm
Height	40 mm	± 0.5 mm
Thickness	4 mm	± 0.2 mm
Length	3,000 mm	± 10 mm

ANNAPURNA 80 X 40

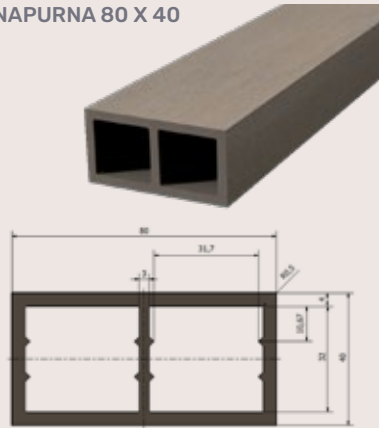

	Value	Tolerance
Weight	1,680 g/mL	± 50 g/m
Width	80 mm	± 0.5 mm
Height	40 mm	± 0.5 mm
Thickness	4 mm	± 0.2 mm
Length	3,000 mm	± 10 mm

ANNAPURNA 160 X 40

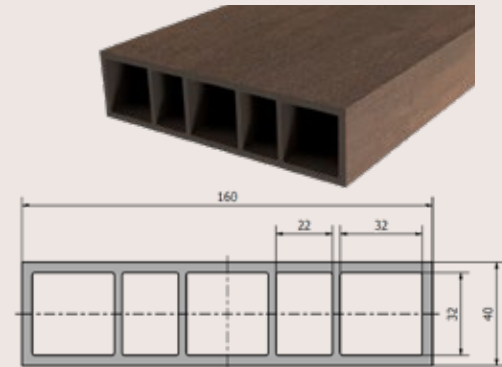

	Value	Tolerance
Weight	3,200 g/mL	± 50 g/m
Width	160 mm	± 0.5 mm
Height	40 mm	± 0.5 mm
Thickness	4 mm	± 0.2 mm
Length	3,000 mm	± 10 mm

K2

K2 110 X 15

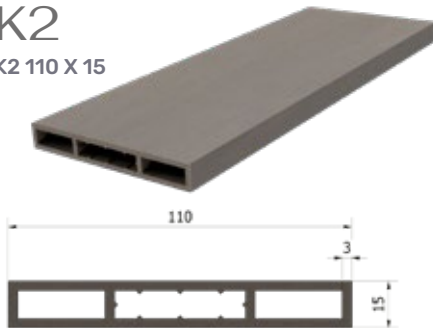

	Value	Tolerance
Weight	1,190 g/mL	± 50 g/m
Width	110 mm	± 0.5 mm
Height	15 mm	± 0.5 mm
Thickness	3 mm	± 0.2 mm
Length	3,000 mm	± 10 mm

ANNAPURNA 80 X 80

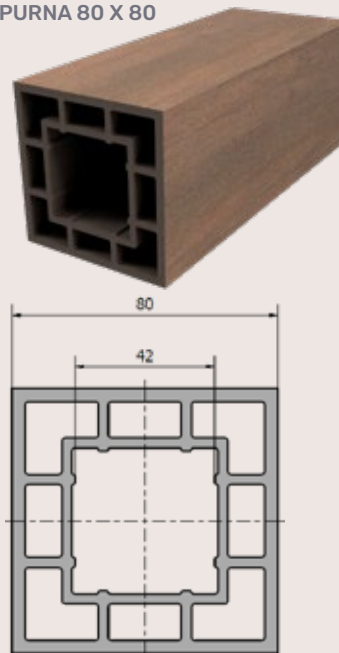

	Value	Tolerance
Weight	3,210 g/mL	± 50 g/m
Width	80 mm	± 0.5 mm
Height	80 mm	± 0.5 mm
Thickness	4 mm	± 0.2 mm
Length	3,000 mm	± 10 mm

ANNAPURNA Rodium



	Value	Tolerance
Weight	900 g/mL	± 50 g/m
Width	50 mm	± 0.5 mm
Height	50 mm	± 0.5 mm
Thickness	4 mm	± 0.2 mm
Length	3,000 mm	± 10 mm

Aluminium profiles

MOUNTING PROFILES DECORATIVE PROFILES

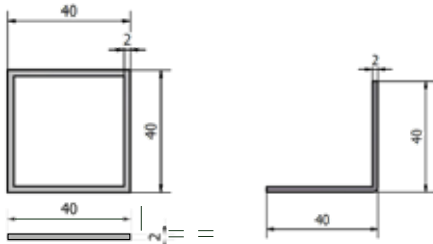

Matt black lacquer

	Tube 40	Angle 40	Platen 40	Tolerance
Weight	821 g/mL	421 g/mL	253 g/mL	± 5 g/mL
Dimensions	40x40 mm	40 mm	40 mm	± 0.5 mm
Thickness	2 mm	2 mm	2 mm	± 0.2 mm
Length	3,000 mm	3,000 mm	3,000 mm	± 10 mm
Units box	20	20	20	-

Chemical composition: EN AW 6005 T6 Alloy
Alloy chemical composition Standard S/EN 573-3

	Si	Fe	Cu	Mn	Mg	Cr	Zn	Ti
	0.50-0.90	0.35	0.5	0.5	0.40-0.70	0.30	0.20	0.10

Kod 40

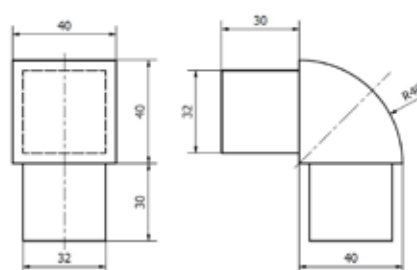

BASTION Accessories

BASTION Pole

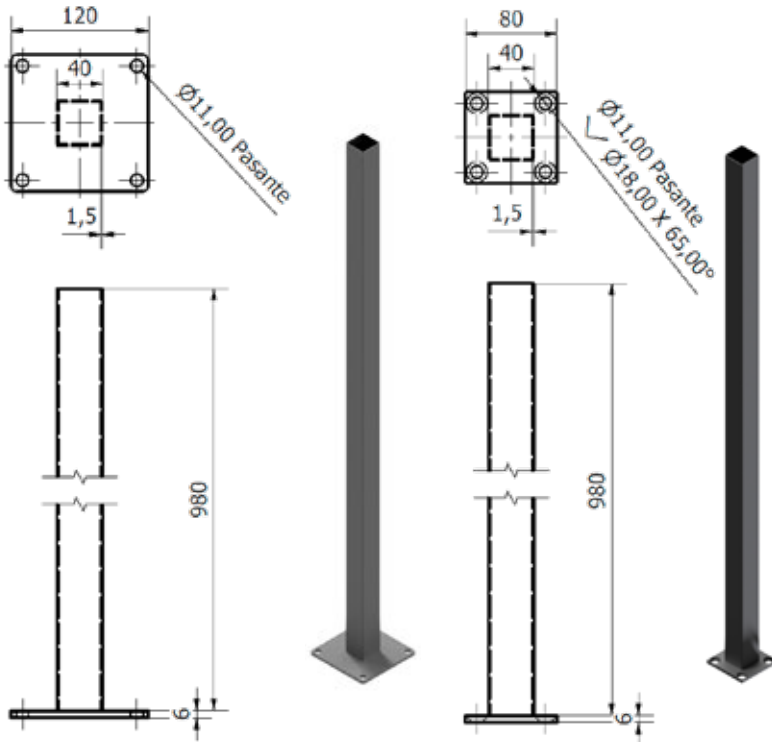

Material: Black lacquered oven-cured galvanized steel.

	Post 80	Post 120	Tolerance
Weight	40 g/unit	9 g/unit	± 50 g/mL
Base	80x80x6 mm	120x120x6 mm	± 1 mm
Height	986 mm	986 mm	± 1 mm
Tube	40x40x1.5 mm	40x40x1.5 mm	± 1 mm
Service	Units	Units	-

BASTION cover and base

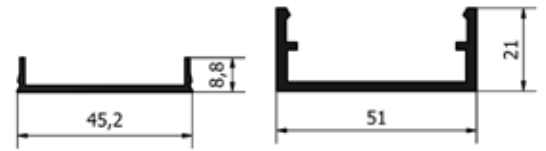

BASTION Cover

BASTION Base

Material: Black lacquered aluminium.

	BASTION Cover	BASTION Base	Tolerance
Weight	257 g/mL	635 g/mL	± 5 g/mL
Length	3 m	3 m	± 5 mm
Service	Units	Units	-

Screw DIN 7981 4x40 mm

Material: AISI 304 stainless steel.

	BASTION Cover	Tolerance
Weight	1,078.9 g/1,000 units.	± 5 g
Measure	4x40 mm	± 5 mm
Service	200 units	± 1 unit

End Cap 50x20 mm



Technical data

PHYSICAL AND MECHANICAL PROPERTIES	MET. TEST	VALUE
Coefficient of linear expansion	UNE 53126	2.84 · 10 ⁻⁵
Modulus of elasticity	UNE-EN ISO 178	4,675 Mpa
Bending strength	UNE-EN ISO 178	29.4 Mpa
Arrow at maximum force	UNE-EN ISO 178	2.9 mm
Brinell hardness	UNE-EN 1534	179.95 HB (N/mm ²)
Water absorption (24 h. in water at 20 °C ± 2°C)	UNE-EN 317	0.99%
Water absorption (28 days in water at 20 °C ± 2°C)	UNE-EN 317	1.78%
Temperature Vicat	UNE-EN ISO 306	87.4%
Density	UNE-EN ISO 1183-1	1.54 g/cm ³
Impact resistance	UNE-EN ISO 477	>5J
Determination of bending temperature under load	ISO 75-2:2005	80.3±0.7°C
Resistance to salt spray - Variation ΔE	UNE-EN ISO 9227	1.25 ΔE
Resistance to basidiomycete fungi	UNE-ENV 12038	Non-attackable
Resistance to soft rot fungus	CEN/TS 15083-2	Non-attackable
Classification of Reaction to fire	UNE-EN 13501-1:2007	B-s3, d0
VOCs	ISO 16000-AgBB- EN 16516	Not detected

Available colours

Blanco	Cemento	Wengué	Arena	Gris
2217	2216	2204	2215	2214

Nogal	Teka	Silver	Castaña	Green-wood	Roble	Ipe
2321	2326	2332	2333	2350	2349	2348

Polar	Sándalo	Luna	Cinnamon	Cozumel	Nielsen	Habanna
2347	2361	2364	2365	2377	2481	2482

There may be slight variations in the colour and surface finish, giving the decking a more natural finish. After a few months of exposure to the elements, as with wood, the colours lighten slightly, making the colour more uniform and stable.

Composition

Tarimatec's raw material is ECO Fiber STONE, composed of PVC, rice husk and crushed marble. This makes a product that combines the best properties of both materials, guaranteeing a long life cycle, with no need for maintenance.

Environmental Information

Unlike other brands, the vegetable fibres used in the manufacture of the Tarimatec® cover do not come from the felling of trees, but are obtained from the reuse of by-products from the cultivation of cereals. It is totally recyclable.

INSTALLATION

ARIS



Assembly instructions

These assembly instructions are designed for the correct installation of the ARIS decorative profile, so that you can enjoy your product with all the guarantees of durability and good performance.

Please read the instructions before installation.

Project

Jaime Salvá Arquitectos

Photograph

Marie-Caroline Lucat

Substrate / support condition

The ARIS profile can be used as a wall cladding system, which can be installed on battens, or directly on the wall (only in interiors), if it is free of humidity, perfectly flat and allows the use of mechanical fasteners and/or adhesives.

WARNING

The condition of the installation substrate is vital for a good performance of the product, as well as to ensure the safety of the installation. Tarimatec is not responsible for the stability of the installation, in terms of the possibility of the batten fastening screws coming loose, and the installer is responsible for guaranteeing this point.



Indoor installation - Mounting elements

For the installation of the Aris profile, the necessary mounting elements are as follows:

<p>Aris profile (according to size)</p>	<p>WPC 45x15 mm inner liner</p>	<p>Screw strip WPC 7505B 4x16 mm</p>	<p>Corner piece 32 x 4 mm</p>
---	-------------------------------------	--	---------------------------------------

All these mounting elements are supplied by Tarimatec®



The 45x15 mm strip is only suitable for indoor installations. For outdoor installations, the Tarimatec® Deck 50x30 mm strip should be used. Please refer to the installation instructions for the ARIS profile for outdoor installation.

Indoor installation

Battening

The Aris profile, in interiors, can be installed directly on the wall, as mentioned above in the conditions indicated, and also on battens. Regardless of whether the profile is installed with or without battens, the substrate where it is to be installed must be stable to allow and guarantee the fastening of the screws. The surface must be level, since the battens are placed directly on it.

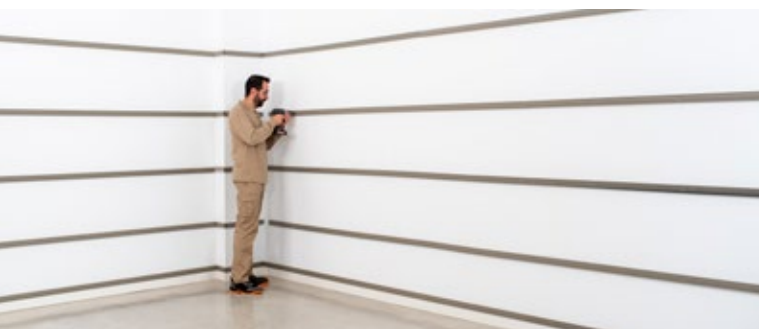

The screw for fastening the battens to the substrate must be chosen by the site management according to the type of substrate.

The battens are placed at a maximum distance of 500 mm from axis to axis. As shown in the image above, small gaps should be left to allow for ventilation.



The battens shall be fastened to the substrate by means of appropriate mechanical fasteners. The spacing of these mechanical fasteners shall not exceed 750 mm. If a batten is less than 750 mm long, it shall have at least two fastenings.



Once the battens are in place, an initial profile is obtained from one of the Aris profiles, by cutting longitudinally the profile's fastening flange, to the size indicated in the following image. The rest of the Aris profile will be used in other parts of the installation, as shown below.

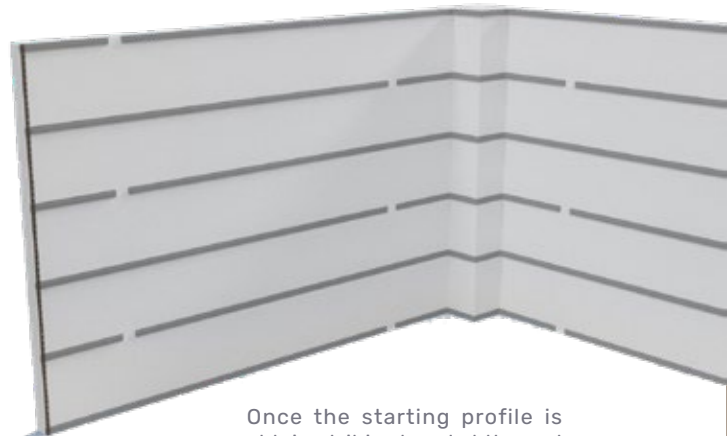
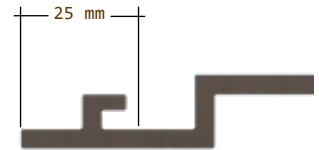

Once the starting profile is obtained, it is placed at the end of the installation to start the assembly of the profiles.

The initial profile is fixed to the strip by means of the Aris fastening screw.



Profile placement

Once the initial profile has been placed, the first Aris profile is placed as shown in the following images.

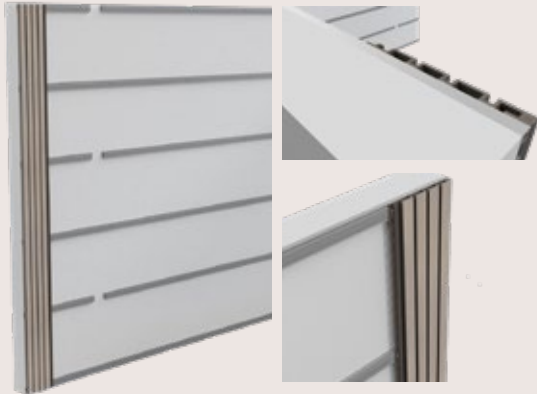

The slat is hooked on the left side into the initial profile, and screwed on the right side with the Aris screw into each of the battens.



For a better performance of the profile, it is advisable that the Aris profile is not in contact with the floor and the ceiling, so a separation joint of at least 5 mm should be left.

The panels are placed until we reach the corner where the pillar is located, and where, normally, we will always have to cut part of the last profile to cover the entire wall.

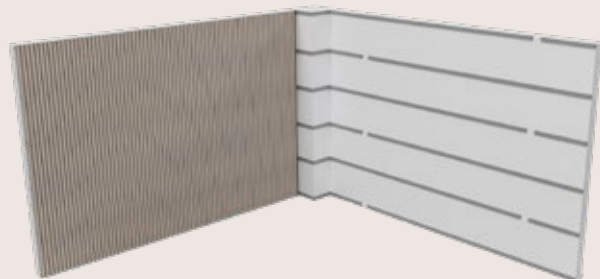

As can be seen in the previous image, the last panel installed does not cover the entire wall, especially considering that the part of the fastening profile should not be visible..

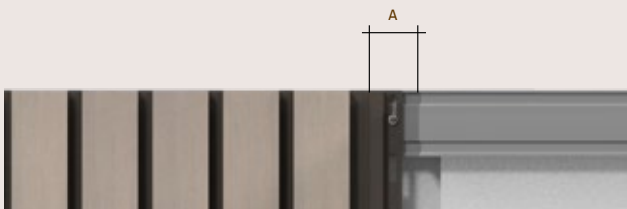

From the same Aris profile from which we have obtained the starting profile, we cut the piece of profile necessary to cover the entire wall. The measure to be cut is "A" + 4 mm.

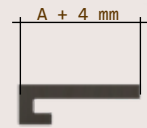

Once cut, it is placed on the fixing flange of the previous profile. It is advisable to apply PVC adhesive on this fixing flap, which will provide the necessary fastening to this cut profile. In the case that when the profile is cut to size A + 4 mm, the recalled profile rests on the strip, double-sided tape or PVC adhesive mentioned above can be applied to the base of the profile.



In the previous image, you can see the finish, which allows us to cover the entire first wall of the installation.

At this point, we repeat the process as when we started the installation on the first wall. We place the starting profile, but in this case, with a different size.

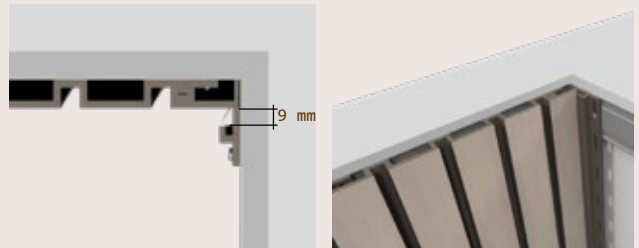

These, at least 9 mm, will allow us to place the first slat that will cover the pillar of the installation, as shown in the following images.

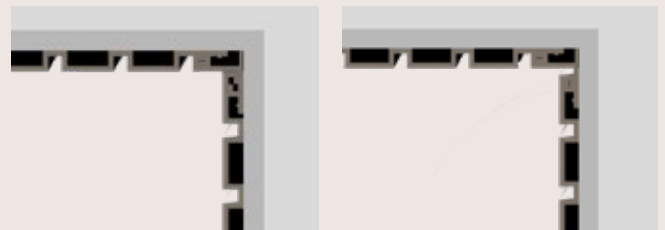

To continue, we would leave, for the moment, the lining of the pillar, and we would start, as before, the installation on the previous panel.

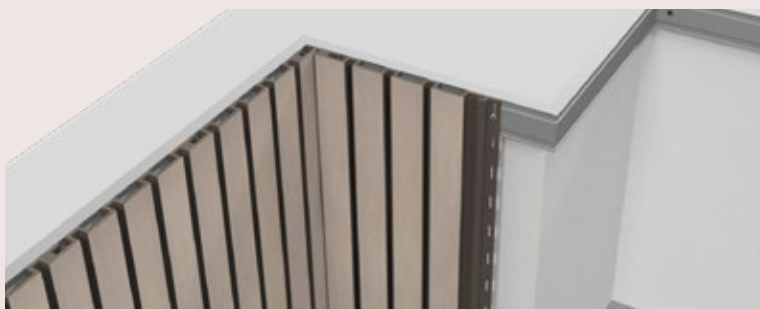

As shown in the following image, we would place the starting profile, obtained from an Aris profile, and we would place the first panel, in the same way as before, screwing in each one of them of the battens



We place the rest of the panels, until the entire wall is covered.

As in the previous case, the last slat will not be enough to cover the wall, we will take the slat that we have used to obtain a starting profile, and we will use it to cover the rest of the wall. As shown in the following image, the fin of the piece of profile used, touches the strip, so it could be fixed, using double-sided tape, or screwing the fin to the strip.

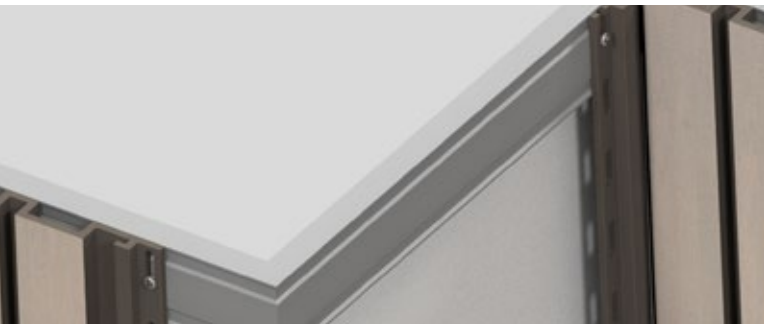

It can also be seen in the previous image that we have already placed a starting profile to finish the lining of the pillar. As in the previous case, we will leave, at least, a gap of 9 mm, to be able to introduce the fastening flap of the next panel.

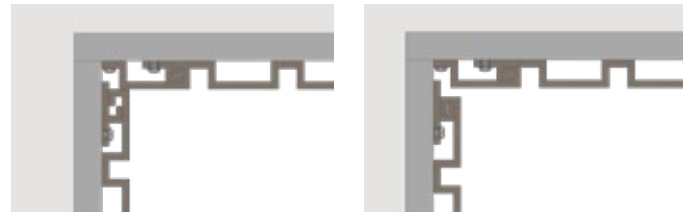
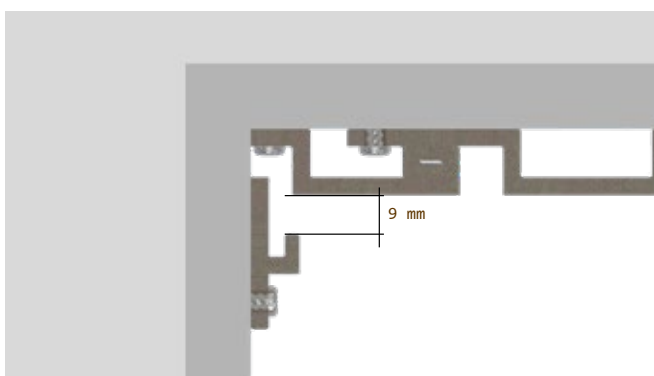

We place the slat, and screw it in the same way as the previous panels, and only the finishing of the corner of the pillar remains to be solved.

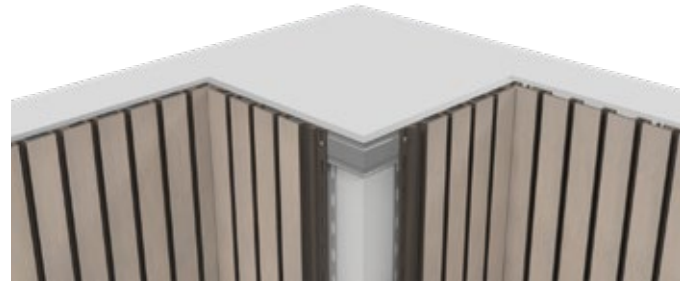

At this point, there would be different ways to solve the column lining, depending on where we have to cut longitudinally the Aris profile. In this case, it would be as follows:



As shown in the image, we cut the profiles to a sufficient size to cover the side of the pillar to be lined up to the end of the batten, which as we can see in the two previous images, and in the following one, in the area of the corner of the pillar, the rails have been cut at a 45° mitre to facilitate the installation.

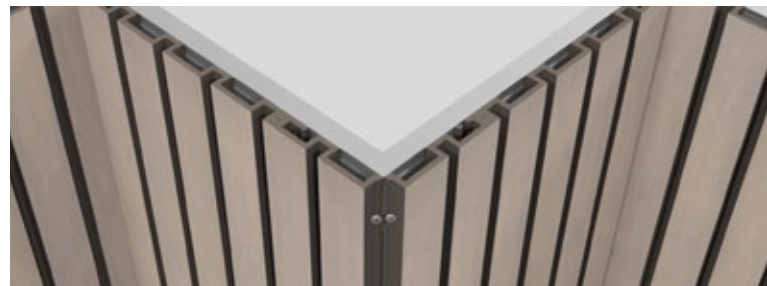

To facilitate the fastening with screws here, we drill a pre-drilled hole at 45° through the Aris profile and the strip. In this case, the Aris screw can be used to fix at the end, as shown in the picture above. Alternatively, adhesives or double-sided tape can be used to ensure fastening.

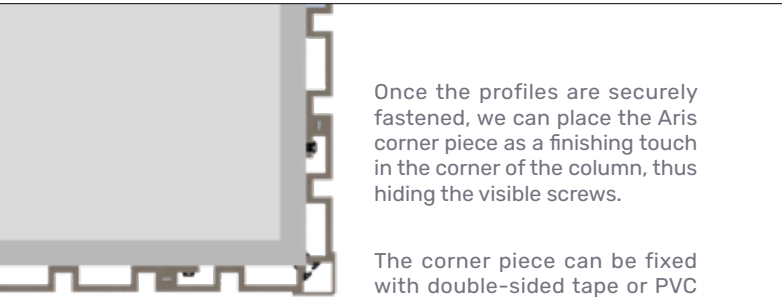

Once the profiles are securely fastened, we can place the Aris corner piece as a finishing touch in the corner of the column, thus hiding the visible screws.

The corner piece can be fixed with double-sided tape or PVC adhesive.

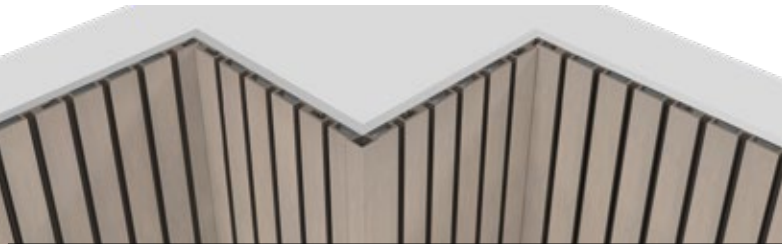

Alternative terminations can be made without the use of the corner piece, which would have to be optimized by the installer in the particular situation of each construction site, but with the appropriate technical means.

Here are two examples of how to make these connections at the corners of the columns. In this case, the installation would start at the columns.

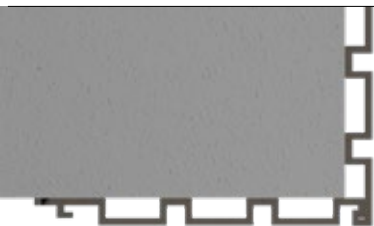

In this case a profile would be cut out, as shown in the picture above, so that it can fit into the anchoring flange of the other profile. It would be fixed along the fin with PVC adhesive.

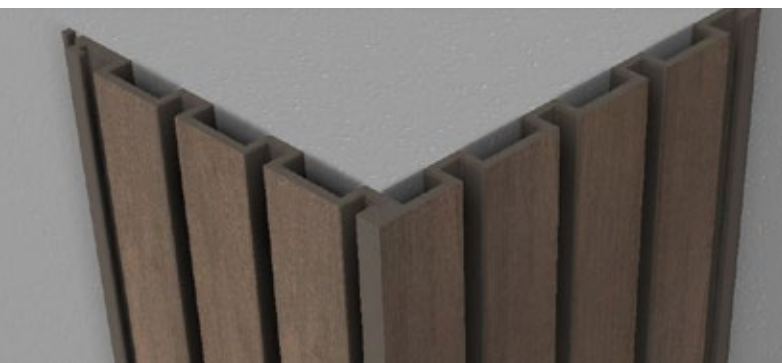

In the following example, a panel is cut so as to maximize the contact between the two in order to make a PVC adhesive fastening along the profile..

In the case of Nature finish, the remaining unbrushed strip can be sanded with 60 grit sandpaper to even out the finish.

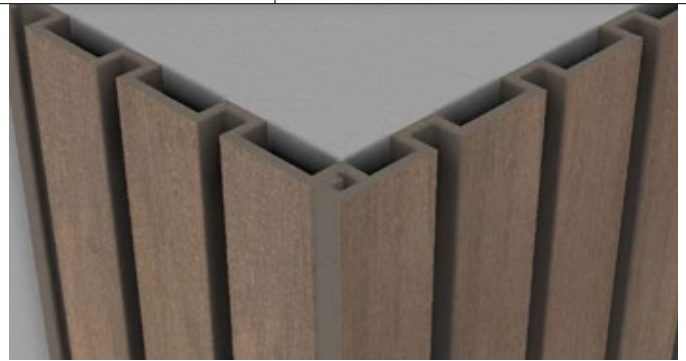

In the case of ARIS ONNA, the solution, both for obtaining the starting profile and in corners, can be the following examples:

As far as the initial profile in ARIS ONNA is concerned, it can be obtained in two ways:



These profiles would be obtained by cutting longitudinally the profile in the areas indicated below, depending on the type of starting profile we want to obtain.



After the cut, using sandpaper, the sharp edge that would remain can be removed, so that this area is rounded and in line with the shape of the profile.



Once the starting profile is obtained, the installation method is the same as the other ARIS profiles, with a tongue and groove method of inserting the flange, instead of the hooking method of the other two models.



As for the corner joints, as in the other models, different joining solutions are possible, by machining, assembling and joining with PVC adhesive. Some examples are shown below.

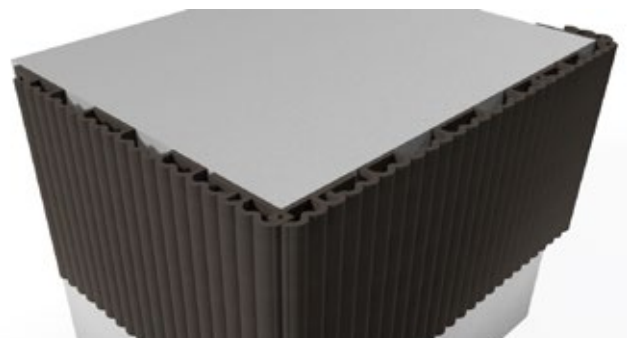

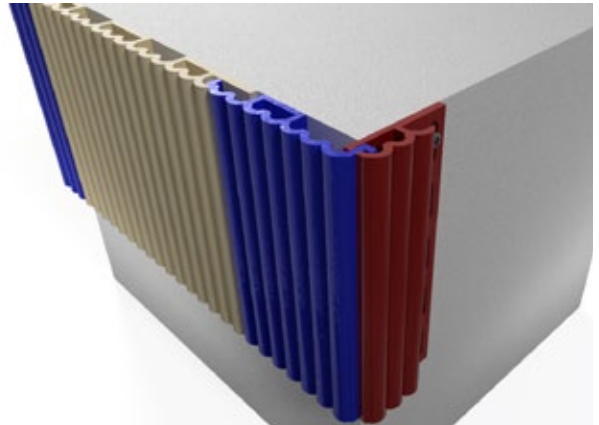
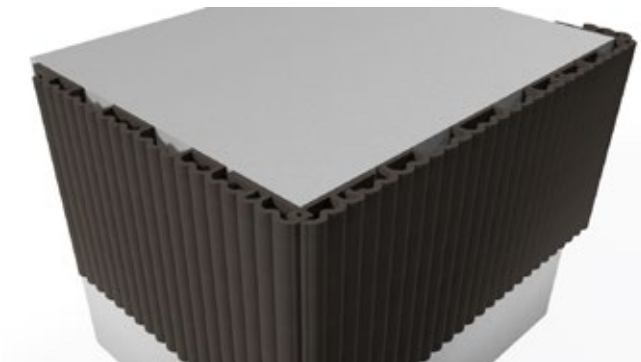

In the following images, the parts used are shown in different colours to better distinguish each part and the solutions shown, as an example.

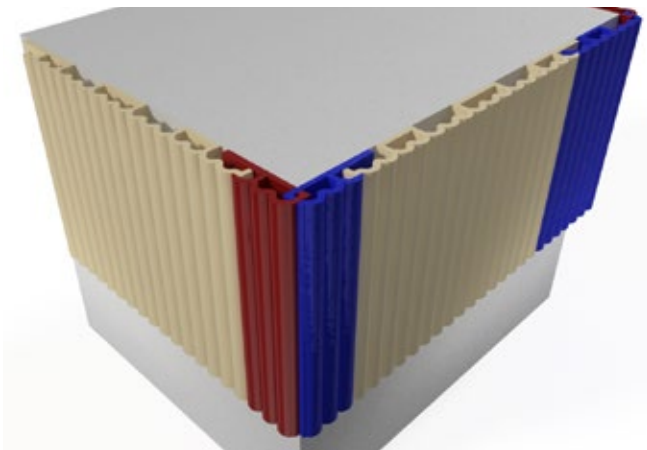





These examples are solutions that can be provided by installers, who have to guarantee the proper functioning thereof. Tarimatec is not responsible for their behaviour.



Outdoor installation - Mounting elements

For the installation of the Aris profile outdoors, the necessary mounting elements are as follows:

 <p>Aris profile (according to size)</p>	 <p>Aluminium exterior strip 50x30 mm</p>	 <p>Aluminium strip screw 7504N 4.2x19 mm</p>
 <p>Angle 40x40 mm Aluminium</p>	 <p>Profile screw end</p>	 <p>Finishing profile</p>

Although ARIS installation is especially suitable for interiors, it is also possible to install the profile outdoors, taking into account that outdoors, only profiles with a NATURE finish can be installed.



Do not install TRAMA finish in outdoors installations

Outdoor installation

Battening

Tarimatec aluminium 50x30 mm battens are used for outdoor installations. The maximum spacing between battens is 500 mm from batten centre to batten centre. If installed as a false ceiling, it is recommended to reduce the distance between battens by about 30%.

It is also advisable to install the profiles in closed structures, which, in addition to guaranteeing the stability of the system, greatly facilitates the levelling of the battens.

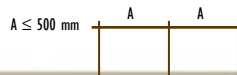

For the realization of closed structures, use the INOX Tarimatec joining bracket. Fix this bracket with the ARIS aluminium strip screw.

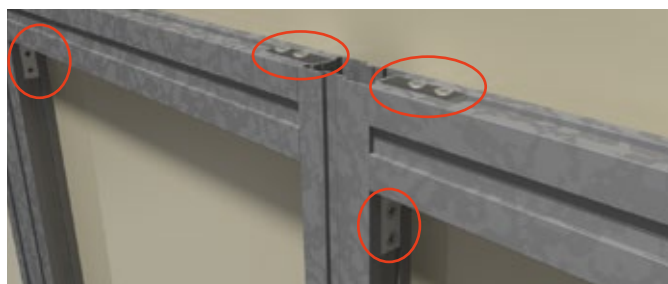

The screw for fastening the battens to the substrate must be chosen by the site management according to the type of substrate.

Profile placement

The installation mode of the ARIS profile is the same as described in the section on indoor installation of ARIS. We place an initial profile, obtained from one of the ARIS panels.

Although ARIS installation is especially suitable for interiors, it is also possible to install the profile outdoors, taking into account that outdoors, only profiles with a NATURE finish can be installed.

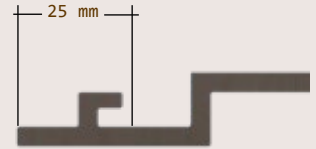

Once the starting profile is obtained, it is placed at the end of the installation to start the assembly of the profiles. In the indoor example, we have placed the ARIS vertically. In this case, we will do it horizontally and start the installation from the top.



We use the 7504N aluminium strip screw for screwing both the initial profile and the ARIS profiles.

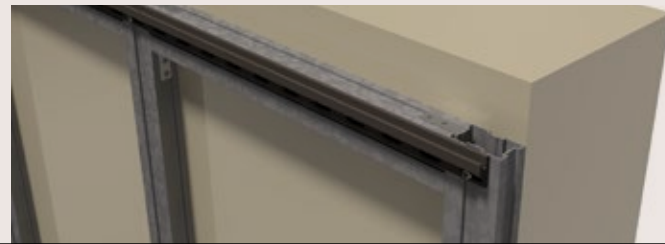

Once the starting profile is fixed, we proceed with the placement of the profiles until we reach a corner, or the end of the installation.



The image on the right shows the first ARIS profile fixed at the top by the initial profile and at the bottom by the self-drilling screw for aluminium strip 7504N.

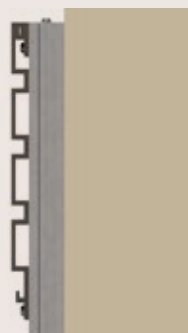

The tightening torque of the screw must be sufficient so that the base of the screw is in contact with the profile, but avoiding that this is nailed and prevent the natural movement of expansions and contractions.



In adjoining panels, both in vertical and horizontal installations, an expansion joint of at least 6 mm must be left. This expansion joint is for planks up to 3 m long. In case of installing longer planks, the size of the expansion joint must be directly proportional to the length of the plank.

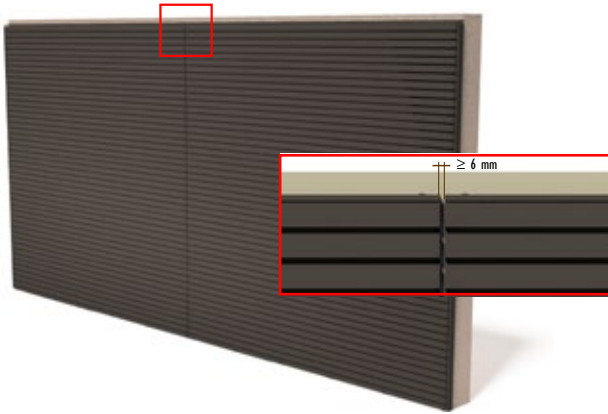

As a finishing touch for the installation, you can use either the finishing profile or the cover strip. Even though this profile is 180 mm wide, it can be cut longitudinally to the desired width and length. This profile will be secured with the cap screw.

This profile will be installed, following the placement instructions, as outlined in the assembly instructions for Tarimatec Deck or Tarimatec Vertical Mont Blanc, provided in this technical manual.



As can be the case with indoor installations, the last plank cannot be laid across its full width. The plank shall be cut lengthwise to the desired width. The minimum gap between the end of the plank and the floor shall be at least 10 mm. In any case, whether on the floor, wall or ceiling, the perimeter joint shall also be 10 mm.



The slat will be fastened at the top by means of the profile's own fastening tab, and at the bottom with the self-drilling screw 7504N. The ARIS profile shall be pre-drilled in the place  where the 6 mm screw is to be placed. Moreover, the tightening torque of the screw shall be the minimum to guarantee the fixing of the ARIS profile to the strip, and allow for the normal expansions and contractions of the profile. The screw should be placed in the centre of the floor.



In exterior installations, when the ARIS profile is installed in HORIZONTAL, the application of the FINISH finish is recommended to reduce the appearance of water stains. However, water stains are easily removed (see Tarimatec cleaning instructions).



BASIC INDICATIONS FOR GOOD PERFORMANCE

It is recommended to make a closed structure, with a maximum batten spacing of 500 mm between batten axes. This separation of 500 mm is recommended to be reduced by 30% when ARIS is installed as a false ceiling.

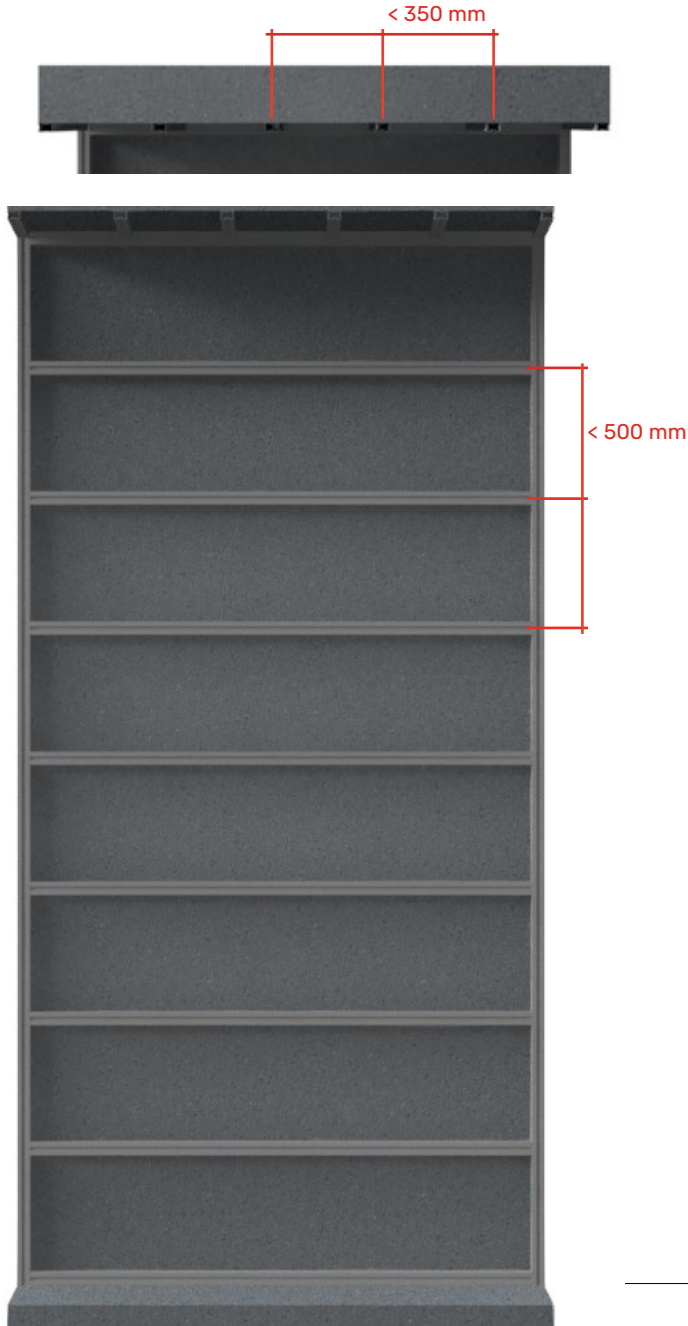

When the ARIS profile is installed with adjoining slats, both horizontally and vertically, the following indications should be taken into account and respected:

Respect the expansion joints, both perimeter and end-to-end of the profile.

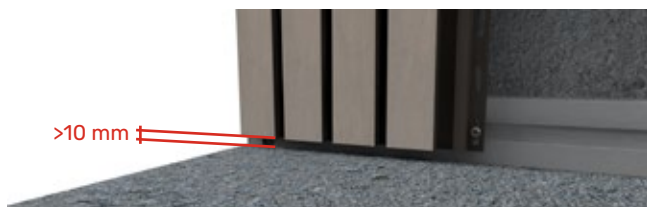

As shown in the images above, the **expansion joint between plank ends** will be **6 mm**, for planks up to 3 m long. Perimeter expansion joints (end-to-ceiling or end-to-floor) will be 10 mm.

The following considerations must be taken into account when fastening the screws:

1. All the screws of the slat, with the exception of the one that fixes the central or most centred strip, shall be placed in such a way that it is fixed in all the strips, and this screw shall be placed in the flap end, with a minimum separation to the end of the strip of 3 mm.



The central or more centred ring nut will be fixed by drilling the fin as shown in the following image.



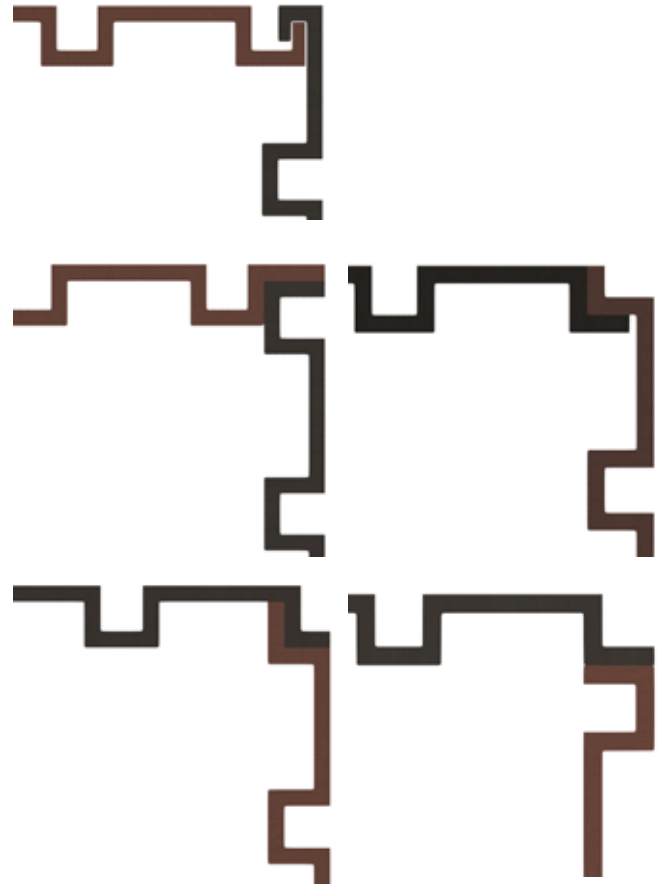
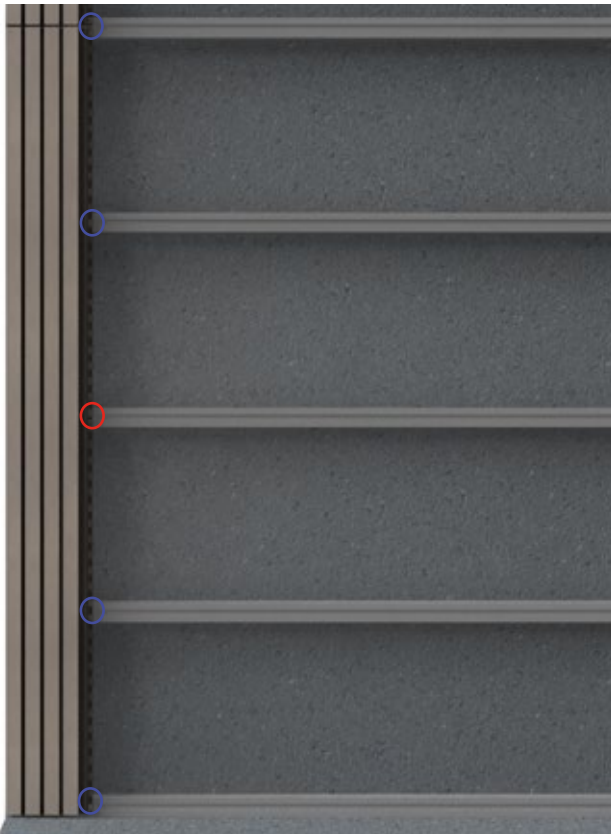

Although the ARIS profile is designed to be installed outdoors and can get wet with rain, no matter how intense it may be, without any problem for this reason, if it is installed as a false ceiling, it must be guaranteed that there are no water filtrations that could cause water to fall and be deposited on its internal face.



At the time of installation, to make the installation more vivid and to avoid cloths with marked shifts in tone, the profiles of different boxes should be obtained during installation, preferably alternating them.

Please note that there may be differences in shade between batches, within the same colour and finish.

Examples of corner assemblies are shown below. These corner assemblies must be made with PVC adhesive, allowing sufficient time for the welding of the two panels to be carried out with guarantees.



TECHNICAL DOCUMENTATION ARIS

Panels

TARIMATEC® ARIS SQUARE- ARIS CADENCE - ARIS ONNA

GENERAL DATA

	Square	Cadence	Onna	Horizon	Tolerance
Weight	1,961 g/m-10.06 Kg/m ²	2,205 g/m-11.31 Kg/m ²	2,040 g/m-11 Kg/m ²	2,879 g/m-10.7 Kg/m ²	± 100 g/m
Width	217.5 mm - 192 mm		214 mm - 192 mm	295 mm - 269.5 mm	± 0.5 mm
Height	15 mm		15.5 mm	15 - 22.05 mm	± 0.5 mm
Length	3,000 mm				± 10 mm

Presentation format: 4 units / box (Horizon:
2 units / box).

NATURE finish: brushed surface. Open pore.
Suitable for both indoor and outdoor use. Available in SQUARE, CADENCE and HORIZON.
SURCO finish: brushed surface. Open pore. Suitable for indoor and outdoor use.
Available in ONNA

TARIMATEC® ARIS SQUARE SECTION VIEW

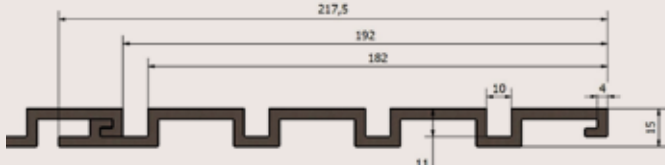

TARIMATEC® ARIS CADENCE SECTION VIEW



TARIMATEC® ARIS ONNA SECTION VIEW



TARIMATEC® ARIS HORIZON SECTION VIEW

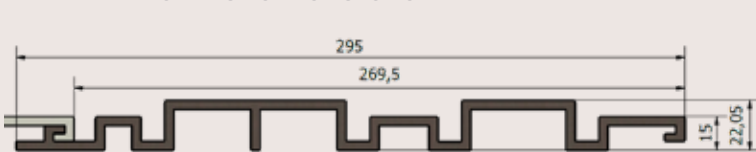

Accessories

*INDOOR INSTALLATION ARIS BATTEN

GENERAL DATA

	Value	Tolerance
Weight	1,383 g/ - 461 g /mL	± 100 g/m
Width	45 mm	± 0.5 mm
Height	15 mm	± 0.5 mm
Length	3,000 mm	± 10 mm

Presentation format: 8 units / pack

Performance: 1 strip / m²
Made from 100% recovered waste materials from processing.

*Strip NOT SUITABLE for levelling, for indoor use only.

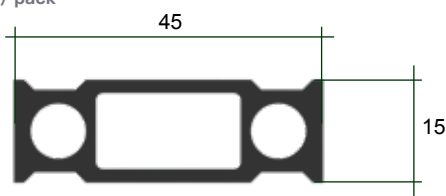

TARIMATEC® ARIS TOP VIEW AND HOLE DETAIL*.

*both models

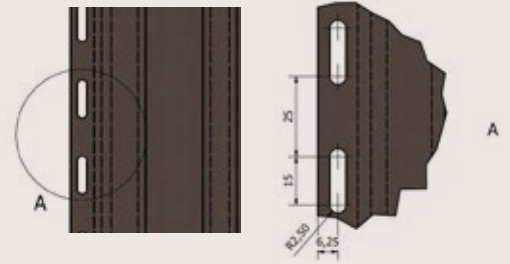

Available colours

Wengué	Ipe	Roble	Luna	Polar	Nogal	Silver
2204	2348	2349	2364	2347	2321	2332

PHYSICAL AND MECHANICAL PROPERTIES	MET. TEST	VALUE
Coefficient of linear expansion	UNE 53126	2.81·10 ⁻⁵
Modulus of elasticity	UNE-EN ISO 178	4,660 Mpa
Indentation Resistance - Brinell Hardness	UNE-EN 1534	179.95 HB (N/mm ²)
Water absorption (28 days in water at 23 °C) ± 2°C	UNE-EN 317	1.663%
Resistance to humidity under cyclical conditions - Var. Flex Resistance (%)	UNE-EN 321	-2.7%
Moisture resistance - boiling test 5 hours - Var. Mass (%)	UNE-EN 15534-1	1.73%
Resistance to salt spray - Variation ΔE	UNE-EN ISO 9227	1.25 ΔE
Determination of thermal shrinkage	UNE-EN 479	0.236%
Temperature Vicat	UNE-EN ISO 306	87.4°C
Density	UNE-EN ISO 1183-1	1.54 g/cm ³
Impact resistance	UNE-EN ISO 477	>10J
Thermodynamic properties by sample DMA - natural loads.	ASTM E1640	Tg=93.19°C
Classification of Reaction to fire	UNE-EN 13501-1:2007	Bs3d0/Bs2d0
Resistance to basidiomycete fungi	UNE-ENV 12038	Non-attackable
Resistance to soft rot fungus	CEN/TS 15083-2	Non-attackable
Pressure and wind suction resistance	EAD 090062-00-0404	> 5,000 Pa
VOC emissions	ISO 16000-AgBB- EN 16516	Not detected



The 45x15 mm strip is only suitable for indoor installations. For outdoor installations, the Tarimatec® aluminium strip must be used.

POZID SCREW DIN 7505B C/ALOM STAINLESS STEEL A2 4 X 16 mm

	Value	Tolerance
Units Box	500	± 5 units.
Materials	Stainless steel AISI 304 A2	



Performance: 15 screws / m²

TARIMATEC® ALUMINIUM STRIP

- Strip A (30x50x3.000 mm)
- 20 units/box

Strip suitable for indoor and outdoor use.

Chemical composition: EN AW 6005 T6 Alloy
Alloy chemical composition Standard S/EN 573-3

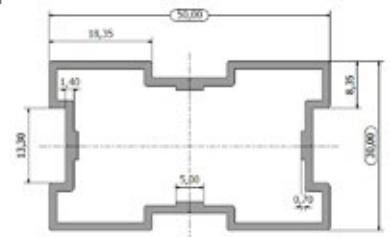

Si	Fe	Cu	Mn	Mg	Cr	Zn	Ti
0.50-0.90	0.35	0.50	0.50	0.40-0.70	0.30	0.20	0.10

Mechanical Characteristics: the UNE-EN 755-2:2009 Standard is applied, EN AW 6005 for Treatment State T6 and thickness of measurements in mm < 5: Tensile strength (Rm) 255 Mpa / Elastic Limit (Rp0.2) 215 MPa / Elongation (A) 8 % / Applicable dimensional tolerances according to UNE-EN 755-9:200

**SELF DRILLING SCREW DIN 7504N C/
ALOM INOX A2 4.2 X 19 mm**

	Value	Tolerance
Units Box	500	± 5 units.
Materials	Stainless steel AISI 304 A2	

Performance:
15 screws / m²



Notes

ALUMINIUM BRACKET 40 X 40 mm

Connecting element Strip
(30 x 50 mm)
Aluminium
Packs of 10 units.
Fastening with screws
DIN 7504 P A2 H 4.2 X 22 mm

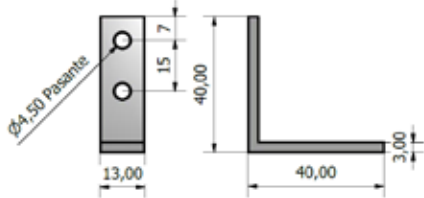

CONNECTING PLATE

Straight Connecting Element
Batten A
(30 x 50 mm)
Aluminium
Packs of 10 units.
Fastening with screws
DIN 7504 P A2 H 4.2 X 22 mm

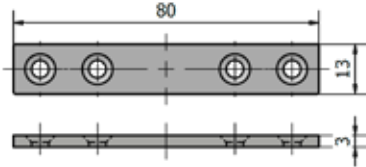

32 X 32 mm EDGER

	Value	Tolerance
Weight	350 g /m	± 100 g/m
Side	32 mm	± 0.5 mm
Thickness	4 mm	± 0.2 mm
Length	3,000 mm	± 10 mm

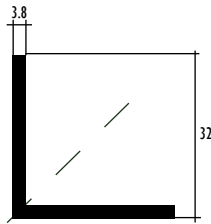

WPC available in the same colours
as the ARIS profiles

END PROFILE

	Value	Tolerance
Weight	2,600 g/m.	± 100 g/m
Width	180 mm	± 5 mm
Height	10 mm	± 0.5 mm
Length	3,000 mm	± 10 mm

Available colours

Wengué	Ipe	Roble	Luna	Polar	Nogal	Silver
2204	2348	2349	2364	2347	2321	2332



There may be slight variations in the colour and surface finish, giving the decking a more natural finish. After a few months of exposure to the elements, as with wood, the colours lighten slightly, making the colour more uniform and stable

Composition

Tarimatec's raw material is ECO Fiber STONE, composed of PVC, rice husk and crushed marble. This makes a product that combines the best properties of both materials, guaranteeing a long life cycle, with no need for maintenance.

Environmental Information

Unlike other brands, the vegetable fibres used in the manufacture of the Tarimatec® cover do not come from the felling of trees, but are obtained from the reuse of by-products from the cultivation of cereals. It is totally recyclable.

INSTALLATION

ARIS MALIBÚ

Assembly instructions

These instructions are intended to ensure that the installation of the ARIS Malibu profile is carried out correctly, so that you can enjoy your product with all the guarantees of durability and good performance.

Please read the instructions before installation.



Assembly elements

In order to install the Aris Malibu profile outdoors, the following fixing elements are required:



Aris profile (according to size)



Aluminium exterior strip 50x30 mm



Aluminium strip screw 7504N 4.2x19 mm



Angle 40x40 mm Aluminium



Corner piece



Profile screw end

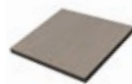

Finishing profile



ARIS Malibu is designed for outdoor installation. However, it can also be installed indoors.

Outdoor installation

Battening

Tarimatec aluminium 50x30 mm battens are used for outdoor installations. The maximum spacing between battens is 500 mm from batten centre to batten centre. **When installed as a suspended ceiling, the maximum distance from batten centre to batten centre is 350 mm.**

It is recommended that the profiles are installed in closed structures, which not only ensures the stability of the system, but also makes it much easier to level the battens.



For the construction of closed structures, use the Tarimatec aluminium connecting bracket. Fix this bracket with the ARIS aluminium strip screw.

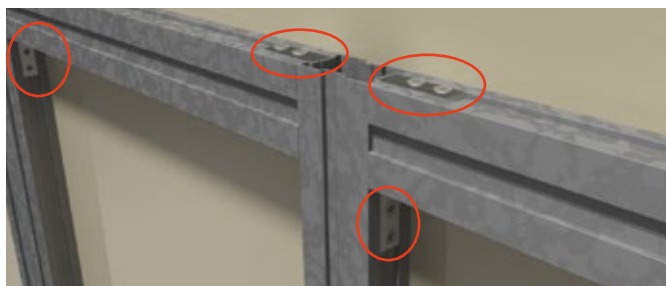

The type and quantity of mechanical fasteners used to fix the battens to the substrate must be chosen by the site supervisor according to the type of substrate.

Profile installation

The installation mode of the ARIS Malibu profile is very similar to the rest of the ARIS family, where the initial profile is obtained from one of the Malibu profiles, as explained in the following image:



The ARIS Malibu panel from which the initial profile has been taken is used to complete the installation. This initial profile is placed at the end of the installation to start the installation of the profiles.



We use the **7504N aluminium strip screw** for screwing both the initial profile and the ARIS profiles.

The distance between the initial profile and the ground must be at least 10 mm.

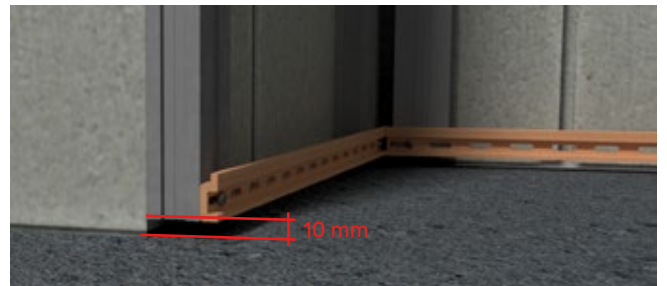

The above screw is used to fix the initial profile to each of the installed slats.



The tightening torque of the screw must be sufficient so that the base of the screw is in contact with the profile, but avoiding that this is nailed and prevent the natural movement of expansions and contractions.

The first ARIS Malibu profile to be installed is fitted into the previously installed initial profile. The ARIS Malibu profiles cannot be in direct contact with the floor, so there must be a gap of at least 10 mm between the profile and the floor.



The top section is fixed using the self-drilling screw 7504N 4.2x19 mm once the bottom section has been fixed to the initial profile.



The screws are inserted into the groove in the fin, all except the central screw, which is inserted through the fin as shown in the following illustration, either by drilling a pre-drilled hole with a 4 mm drill bit in the fin of the profile, or by using the drill point of the screw used.



The rest of the screws shall be fastened using a tightening torque that guarantees the fastening, but does not drive the screw, as this is the only way to avoid lateral displacement of the part. With the screws fastened in this way, normal expansion and contraction of the profiles is allowed, but lateral displacement of the part is avoided.



Except for the central screw of the profile, the rest of the screws must allow the natural expansion and contraction of the profile, placing it in the centre of the groove.



In adjoining panels, both in vertical and horizontal installations, an expansion joint of at least 6 mm must be left. This expansion joint is for planks up to 3 m long. In case of installing longer planks, the size of the expansion joint must be directly proportional to the length of the plank.

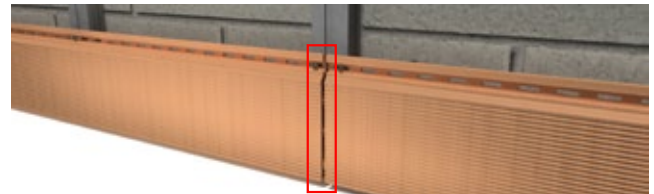

>6 mm

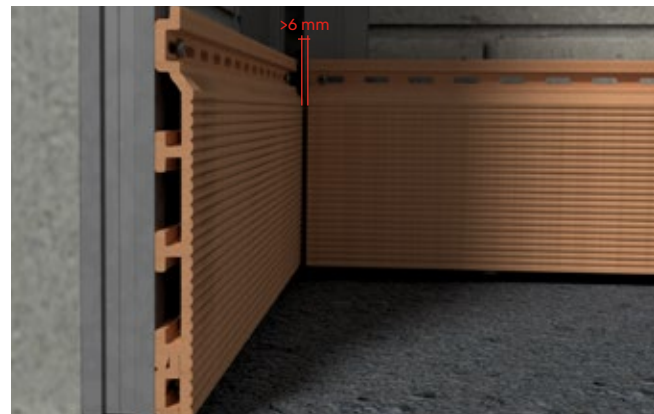

>6 mm

Following these instructions, the boards are laid in a pattern, preferably with a regular joint, as shown in the following image.

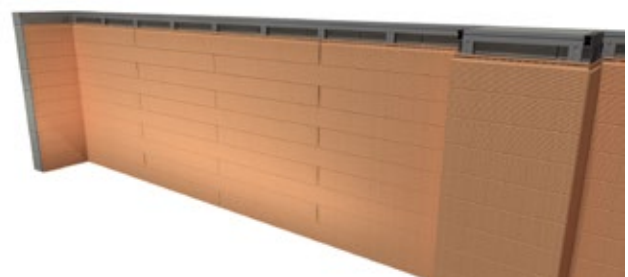

The columns can be mitred as shown in the following image. It is recommended to sand lightly to avoid a sharp edge, especially if the area is accessible.

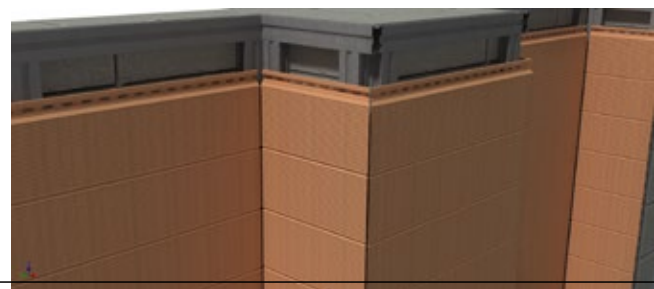



The last row of the installation, it is never possible to finish the installation with a complete piece, so the last piece laid must be cut lengthwise to the required width, depending on the space available.

This end cap is fixed with lacquered end profile screws. The distance between these screws must not exceed 350 mm.

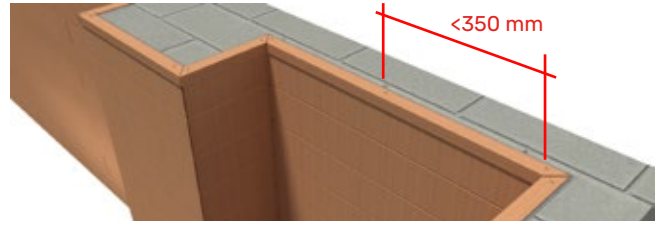

As a side finish, the same corner piece can be used with the same fixing criteria, leaving a 6 mm expansion joint between the top of the Malibu profile and the inside of the corner piece.



In the example shown in the previous image, a mechanical fixing is made to the top plank. As in this example, a 32x32 mm corner piece is used as the top end cap.

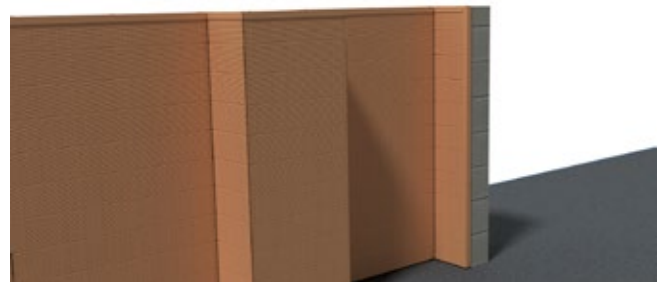

Alternatively, with the same 6 mm expansion joint, the end profile can be used.



The expansion gap to be left with the corner piece and the end profile in relation to the floor must be at least 10 mm.

This fastening shall be carried out with only one screw per plank in the centre of each plank. This is to secure the position of the plank and prevent it from sliding.

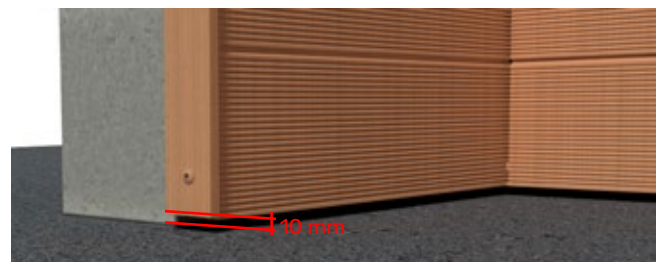

This will complete the installation as shown in the example.

Once the last plank has been fixed, the bracket is placed to make the top edge.

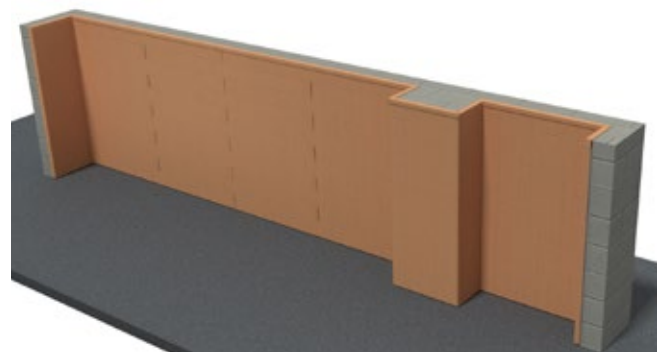

In the event that we need to make 90° assemblies in the longitudinal direction of the piece, creating an edge profile, this can be done with a few simple cuts with a squaring machine and joining both pieces with PVC adhesive. We always look for the largest possible contact surface in the union of the two pieces so that the adhesive performs a guaranteed weld.

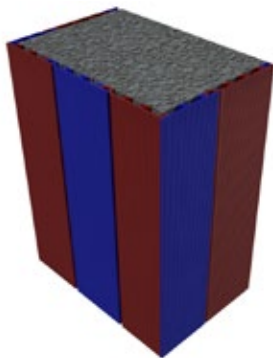
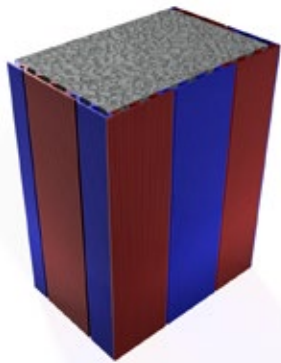
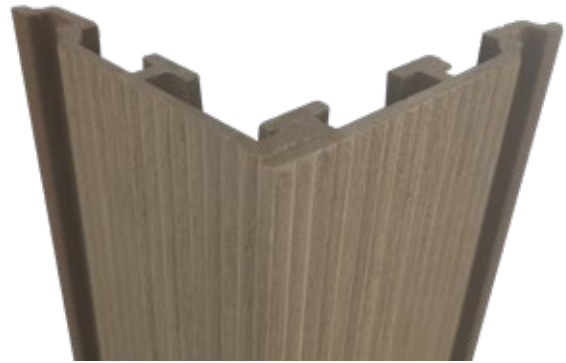

The images above and below show examples of how to join different pieces depending on the length required for the project.

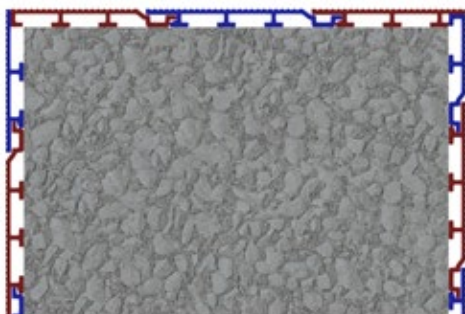

Panels

TARIMATEC® MALIBÚ Surco



GENERAL DATA

	Value MALIBÚ Surco	Tolerance
Weight	1.499 g/m - 11.30 Kg/m ²	± 100 g/m
Width	136.5 mm	± 0.5 mm
Height	15 mm	± 0.5 mm
Length	3,000 mm	± 10 mm

Presentation format: 4 units / box.

SURCO finish: brushed surface. Open pore. Suitable for both indoor and outdoor use.
Performance: 7.53 mL/m²

TARIMATEC® MALIBÚ SECTION VIEW

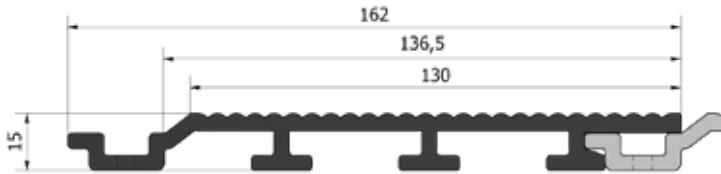

TARIMATEC® MALIBU TOP VIEW AND HOLE DETAILS

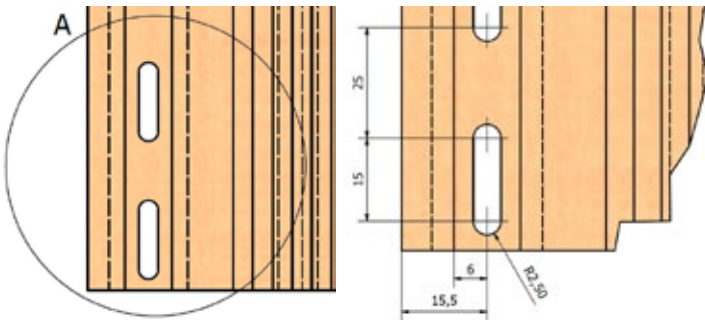

Available colours MALIBÚ SURCO

Nogal	Teka	Silver	Castaño	Greenwood	Roble	Ipe
2321	2326	2332	2333	2350	2349	2348
Polar	Sándalo	Luna	Cinnamon	Cozumel	Nielsen	Habanna
2347	2361	2364	2365	2377	2481	2482

PHYSICAL AND MECHANICAL PROPERTIES	MET. TEST	NATURE / TRAMA
Coefficient of linear expansion	UNE 53126	2.81·10 ⁻⁵
Modulus of elasticity	UNE-EN ISO 178	4,660 Mpa
Indentation Resistance - Brinell Hardness	UNE-EN 1534	179.95 HB (N/mm ²)
Water absorption (28 days in water at 20°C ± 2°C)	UNE-EN 317	1.663%
Resistance to humidity under cyclical conditions - Var. Flex Resistance (%)	UNE-EN 321	-2.7%
Moisture resistance - boiling test 5 hours - Var. Mass (%)	UNE-EN 15534-1	1.73%
Resistance to salt spray - Variation ΔE	UNE-EN ISO 9227	1.25 ΔE
Determination of thermal shrinkage	UNE-EN 479	0.236%
Temperature Vicat	UNE-EN ISO 306	87.4°C
Density	UNE-EN ISO 1183-1	1.54 g/cm ³
Impact resistance	UNE-EN ISO 477	>10J
Thermodynamic properties by sample DMA - natural loads.	ASTM E1640	Tg=93.19°C
Classification of Reaction to fire	UNE-EN 13501-1:2007	Bs3d0
Resistance to basidiomycete fungi	UNE-ENV 12038	Non-attackable
Resistance to basidiomycete soft rot fungus	CEN/TS 15083-2	Non-attackable
Pressure and wind suction resistance	EAD 090062-00-0404	> 5,000 Pa

Accessories

TARIMATEC® ALUMINIUM STRIP

- STRIP A (30x50x3,000 mm) - 20 units/box
Strip Suitable for indoor and outdoor use
Chemical composition: EN AW 6005 T6 Alloy
Alloy chemical composition Standard S/EN 573-3

Si	Fe	Cu	Mn	Mg	Cr	Zn	Ti
0.50-0.90	0.35	0.50	0.50	0.40-0.70	0.30	0.20	0.10

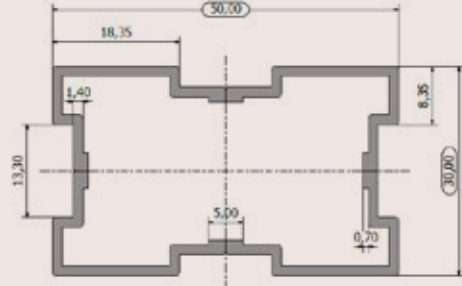

Mechanical Characteristics: the UNE-EN 755-2:2009 Standard is applied, EN AW 6005 for Treatment State T6 and thickness of measurements in mm < 5: Tensile strength (Rm) 255 Mpa / Elastic Limit (Rp0, 2) 215 MPa / Elongation (A) 8 % / Applicable dimensional tolerances according to UNE-EN 755-9:2000

SELF DRILLING SCREW DIN 7504N C/ ALOM INOX A2 4.2 X 19 mm

	Value	Tolerance
Units Box	500	± 5 units.
Materials	Stainless steel AISI 304 A2	

Performance:
15 screws / m²



ALUMINIUM BRACKET 40 X 40 mm

Connecting element Strip A (30 x 50 mm) Stainless steel A2
Packs of 10 units.
Screw fixing
DIN 7504N C/ALOM INOX A" 4.2x19 mm

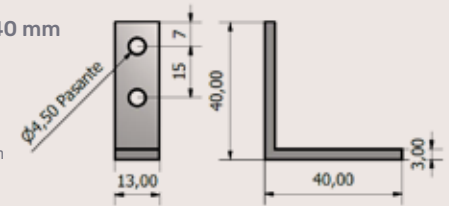

32 X 32 mm EDGER

WPC available in WOOD colours
50 units/box

	Value	Tolerance
Weight	352 g / m	± 5 g/m.
Width	32 mm	± 0,5 mm
Thickness	4 mm	± 0.2 mm
Length	3,000 mm	± 10 mm

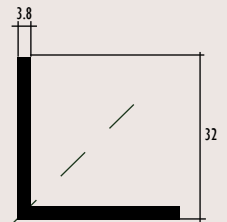

END PROFILE

WPC available in the same colours as MALIBÚ profiles

	Value	Tolerance
Weight	2,600 g/m.	± 100 g/m
Width	180 mm	± 0.5 mm
Height	10 mm	± 0.5 mm
Length	3,000 mm	± 10 mm

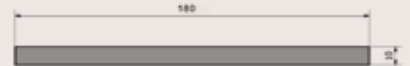

There may be slight variations in the colour and surface finish, giving the decking a more natural finish. After a few months of exposure to the elements, as with wood, the colours lighten slightly, making the colour more uniform and stable

Composition

Tarimatec's raw material is ECO Fiber STONE, composed of PVC, rice husk and crushed marble. This makes a product that combines the best properties of both materials, guaranteeing a long life cycle, with no need for maintenance.

Environmental Information

Unlike other brands, the vegetable fibres used in the manufacture of the Tarimatec® cover do not come from the felling of trees, but are obtained from the reuse of by-products from the cultivation of cereals. It is totally recyclable.

INSTALLATION

DECK - EDGE PROFILE



Assembly instructions

The purpose of these instructions is to show how to cover steps, stairs, planters or other similar elements with Tarimatec. This document should only be used as a guide, and the system must be adapted to the conditions of each project.

This manual is supplementary to the **Tarimatec Floor / Deck Installation Instructions**. For this reason it is assumed that the installer knows and masters the instructions in this respect. Please read the instructions before installation.







State of the support



The support where this type of installation is to be carried out must allow for the screwing of battens, as well as guaranteeing the evacuation of water.

Assembly elements

For the assembly of the "Vertical System" using the Annapurna profile, the necessary mounting components are as follows:

		
Deck 150x28 mm	Batten 50x30 mm	Batten bracket
		
Tapping screw	Initial clip	Tarimatec clip
		
		Screw 7504P 4.2x25 mm

Installation

Battening

The strip must be screwed into the tread and riser of the corresponding stair or step, so that the floor or support must be stable.

The evacuation of water between the steps must be guaranteed to prevent it from becoming trapped and partially or totally submerging the decking. There are two options for this:

- If the strip is screwed directly to the floor, make holes or recesses in the corners of the steps.
- Supplement the battens with wedges to allow water to pass under the battens.



This second option is the one we can see in the Tarimatec Deck installation manual, so in this manual, we will show the first one: making holes or recesses in the edges of the steps.



The first battens are placed on the riser of the first rung. the spacing between battens is not more than 350 mm

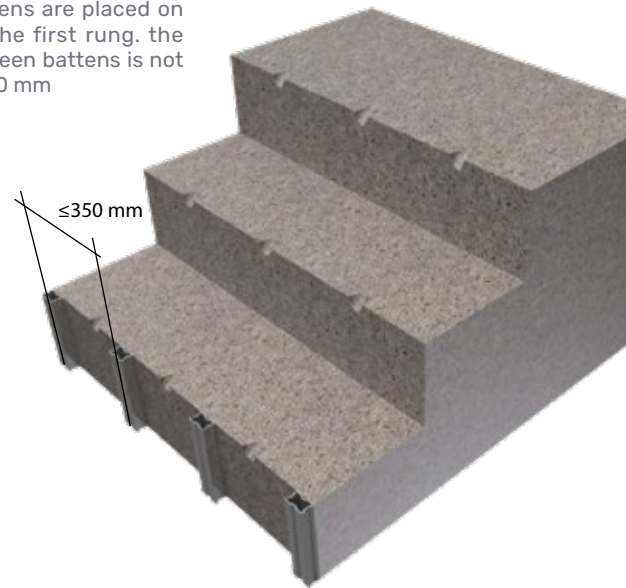

The battens are fastened with a tapping screw in the same way as the screwing of the battens to the floor in the deck installation.



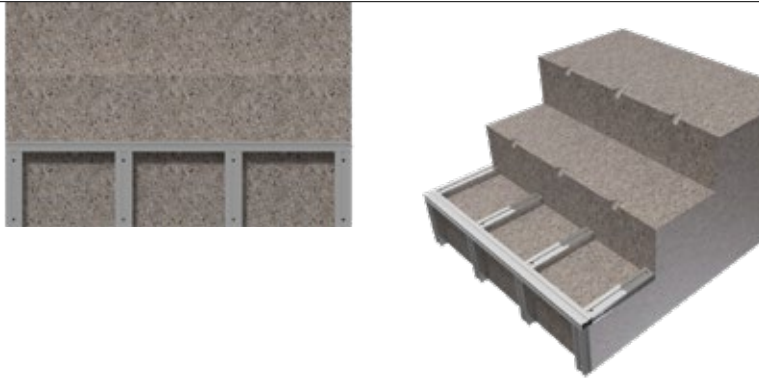

The battens of the tread of the first rung are screwed in using the tapping screw previously seen and the rung edge batten is attached to the battens placed in the tread by means of brackets on both sides of the batten.

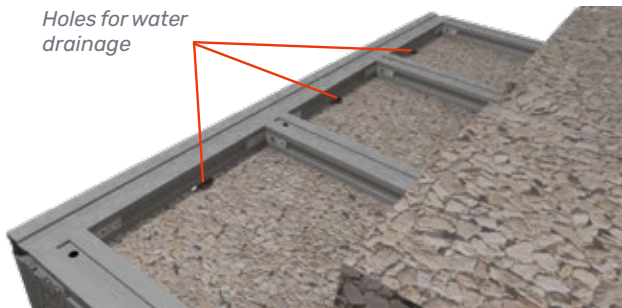

Holes for water drainage

In the previous image, we can see the detail of the fixing of the edge strip with brackets, as well as how it allows the evacuation of water and in the following image we can see how the edge strip is coplanar on two of its faces with both the tread and riser strips.



The battens of the second riser are installed in the same way as in the first riser, resting, as shown in the previous and the following image, on the battens of the tread of the first rung.



From this point onwards, with regard to the stripping, it would be necessary to repeat the above operations as many times as there are steps in the staircase.



For a good performance of the lining, the stability and stiffness of the batten must be guaranteed, as well as an efficient water drainage.

Laying of profiles

Once the profile structure is in place, we proceed to cover the steps. To do this, we place a starter clip on the riser of the first step, perfectly aligned, on each of the battens, separated 10 mm from the floor, as shown in the following images.



10 mm



Once the initial clip is in place, we lay the first plank of decking, which will cover part of the riser of the step.

This decking plank is fastened by its top flap with Tarimatec clips. Both the initial clip and the Tarimatec clip are fixed to the aluminium strip with the 7504P 4.2 x 25 mm screw. Once the first plank has been laid, we can see that the space in the riser is insufficient to accommodate a complete plank, so at this point, we must carry out the machining and assembly of the edge profile.

To do this, we take into account the following measurement, which will be different depending on the tread and riser measurements of the stairs to be covered.

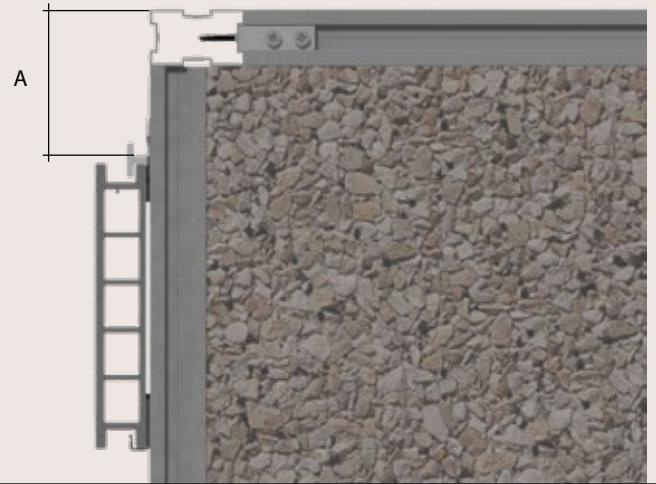

At this point, the assembled edge profile is fitted. The parts are machined and assembled, as shown in the following image.

For the machining of the edge profile, the dimensions shown below are taken into account.

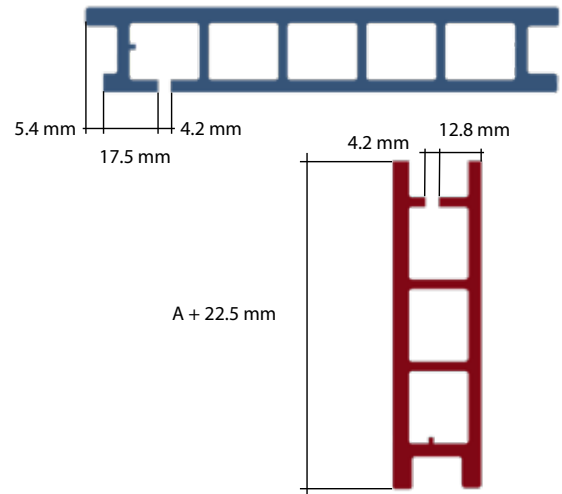
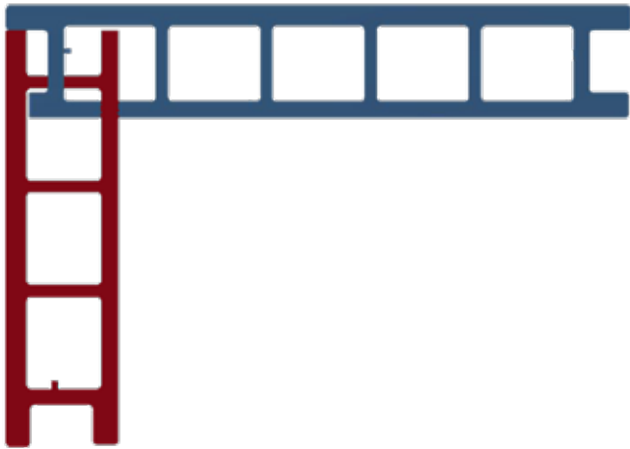

After machining, the parts are assembled by sliding the parts together in the two open grooves. MS adhesive can be used to consolidate the joint.

Once the adhesive has been applied, the edge profile is fixed both on the riser and on the face of the tread of the first step, with the Tarimatec clip, as shown in the following image:

Prior to the installation of the assembled edge profile, 4 beads of MS type adhesive are applied as shown in the following picture:

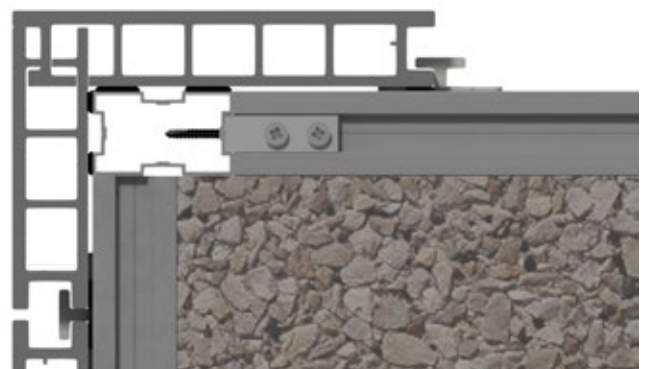
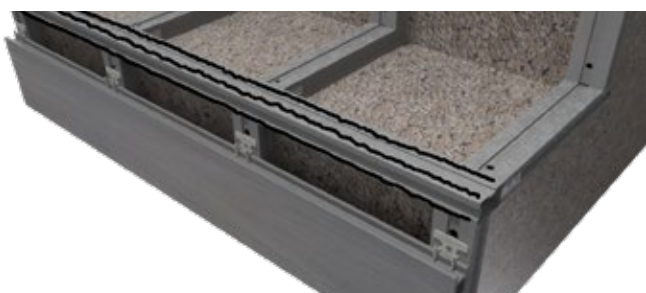



At this point, we proceed to cover the riser of the second step and to do so, we place the clips at the height that will allow us to place the decking.



Once the clips are in place, insert the board, which must be trimmed to fit the size of the edge profile.



After fixing the edge profile, the following plank would be placed to, in this example, completely cover the tread of the first step. This board is also fixed using the Tarimatec clip.

As shown in the picture above and below, the board is fastened on both sides with Tarimatec clips.

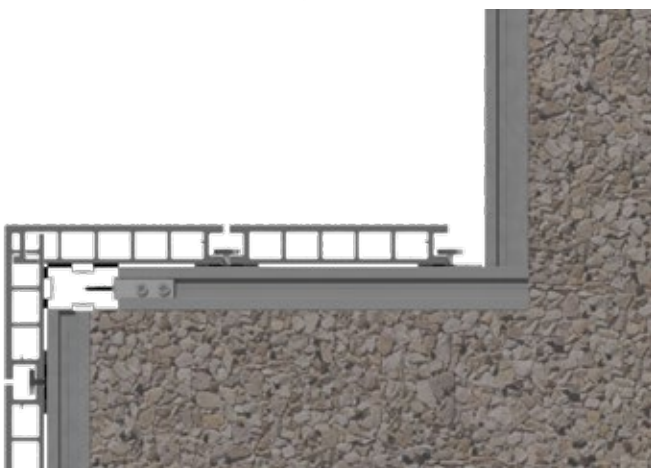
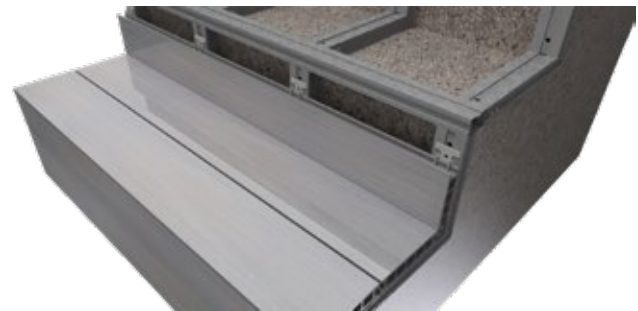

In the same way as for the first step, we would place the MS adhesive on the strip at the edge of the step, and we would then place the handrail. For the riser piece, instead of the conventional clip, a starter clip could also be used, as shown in the following image circled in red.



NOTES



We continue lining in the same way as the previous steps until we have finished the lining of the staircase.

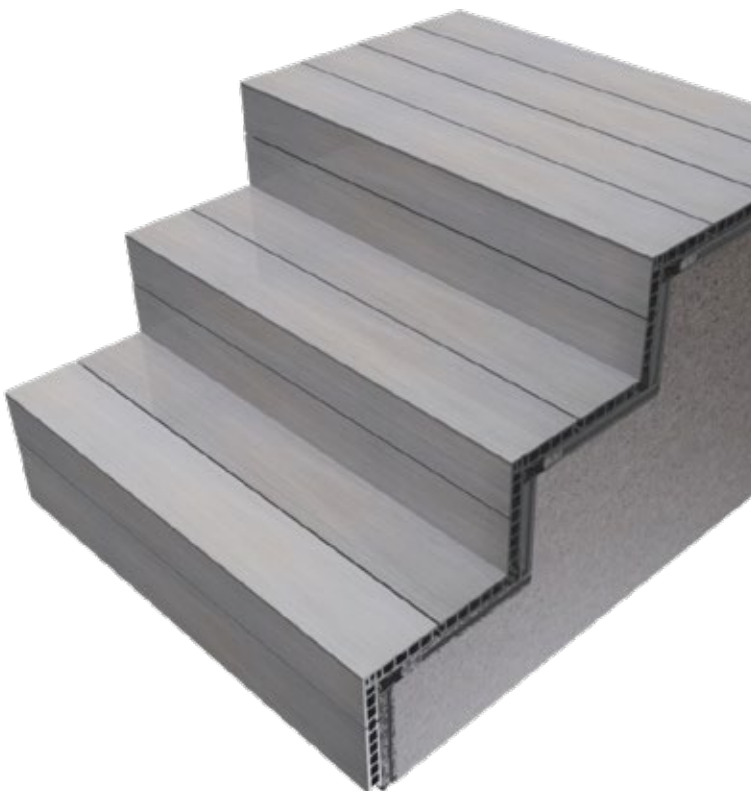
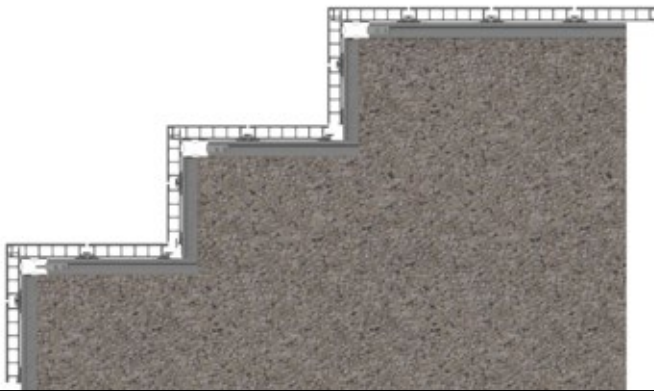

INSTALLATION

VERT. SYSTEM - ANNAPURNA 50X30 mm



Assembly instructions

These assembly instructions are designed to ensure that the installation of the "Annapurna 50x30 mm Vertical System" is carried out correctly, so that you can enjoy your product with all the guarantees of durability and good performance.

Please read the instructions before installation.

Edition 12 25-01-2025

Project
MMA Estudio
Photograph
Alberto Amores

Substrate / support condition

The "Vertical System", as well as being able to be installed **indoors**, is also **suitable for outdoors**, as it is a ventilated façade system, which is installed on battens. These battens are mechanically fixed to the substrate, support or wall, and therefore, this installation base must withstand the placement of structure fastening screws

WARNING

The condition of the installation substrate is vital for a good performance of the product, as well as to ensure the safety of the installation. Tarimatec is not responsible for the state of the substrate of each installation. This section, as well as the quantity and type of fixings to be used, will be determined by the technical management of each project, the one offered here being a standard solution as a decorative profile and not as a ventilated façade. Each ventilated façade installation requires a specific study in this respect.



If the mounting surface is not level, shims, levelling brackets or any other system deemed appropriate shall be used. These elements must be suitable for the intended use and the installer or DF must guarantee their suitability.



In the example shown, the installation battens are fixed to the substrate by means of tapping screws of at least 6 mm. These screws must be made of AISI 304 stainless steel, and AISI 316 if the installation is to be carried out in marine environments.

Assembly elements

For the assembly of the "Vertical System" using the Annapurna profile, the necessary mounting components are as follows:

Annapurna Profile 	MB/Annapurna strip 	Screw-plug 
Initial clip 	Screw 7504P 4.2x25 mm 	Clip MB/Annapurna 
Screw 7505A 2.5x25 mm 	Screw cap 	End profile 

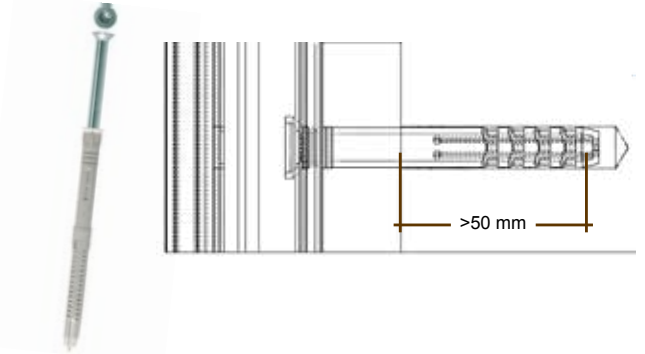

The tapping screw-plug must enter 50 mm into the substrate, so that when the plug expands, correct fastening can be guaranteed. The maximum spacing of the screws fastening the batten to the wall shall be a maximum of 750 mm.



Outdoor and indoor installation

Battening

As mentioned in the previous section, the substrate where the Vertical System is to be installed must be stable to allow and guarantee the fastening of the screws. The surface must be level.



As can be seen in the picture above, a 3 m long strip should be fixed at least 5 equidistant points. This is the minimum permissible fixing. Once this point has been clarified, the maximum separation distance between battens is discussed. At this point it is worth highlighting the presence of the double battens at the ends of the installation, where all the Annapurna profile end pieces coincide, this being one of the critical points of the installation, in outdoor installations.



WARNING The correct levelling of the battens must be ensured in order to guarantee, especially outdoors, the good behaviour of the profiles in the expansions and contractions produced by temperature variations. Incorrect levelling of the battens can hinder the natural movement of the pieces and consequently cause them to arch.

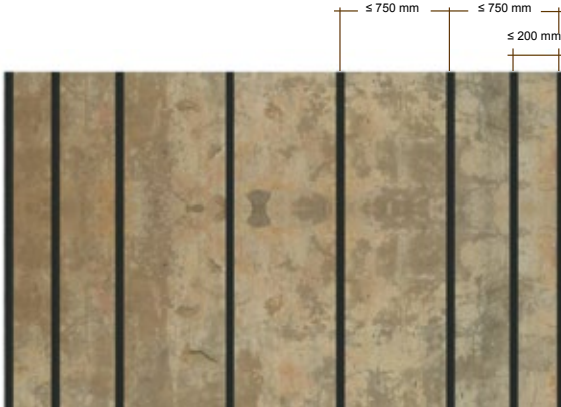

As can be seen in the previous image, the spacing between battens shall not exceed 750 mm. At the ends, between the first and second battens, an intermediate batten shall be placed at a distance of no more than 200 mm from the first batten. In indoor installations, which do not receive direct sunlight, it shall not be necessary to place the intermediate batten at 200 mm. In the upper part of the installation, a horizontal batten can be laid horizontally. This will make it easier to lay the final finishing once the Annapurna profile has been laid. When laying the strip, the profiles should be levelled and it should be checked that the distance between them never exceeds the maximum distance (750 mm).

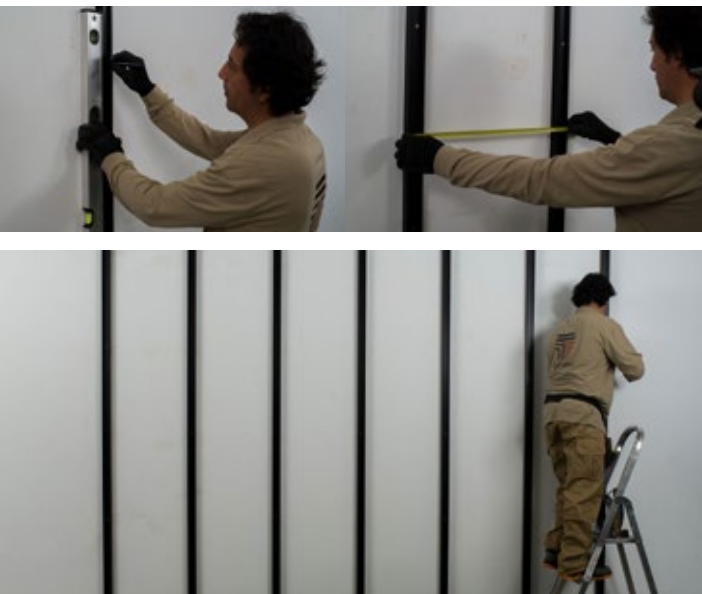

These horizontal battens can be screwed to the same substrate and in the same way as the vertical battens, thus being perfectly fastened and being able to place the appropriate finishing profile on it with total guarantee.

Laying of profiles

Once we have the battens in place, we can start the installation of the Annapurna profile, although first we will need some element to hold the first slat of this profile. This element is the **initial clip**, which will provide us with a good fastening of the slat, with this fastening being completely hidden. The initial profile can be fixed to the batten strip with the screw 7504P A2 4.2 x 25 mm as shown in the picture. If the installation starts from the ground, the initial clip shall be placed at a minimum distance from the ground of 15 mm.



Once the starter clips are in place, we can proceed with the installation of the first Annapurna 50x30 mm profile.

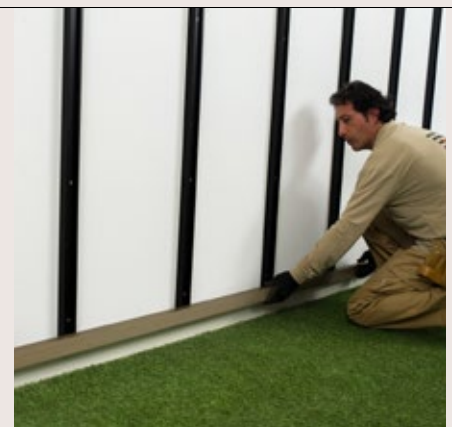

Once the first profile is in place, we fix it on its upper side with the Annapurna clip. The first row of clips will be fixed with screws.

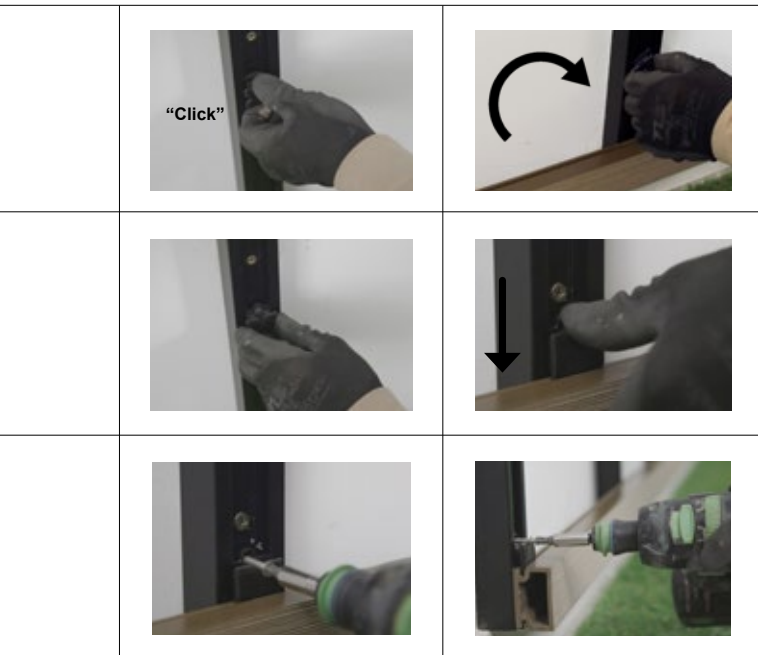

Once the first profile has been installed, the following profiles are installed in the same way, without the use of fixing screws. At row 10, we would place the fastening screws again to ensure the horizontal position and thus avoid a "fan effect" in the upper rows. Repeat in the same way every 10 rows, e.g. row 10, row 20, etc...



Another thing that can happen in façade profiles, due to the natural dimensional variation caused by the expansion and contraction of the profile due to changes in its temperature, is that uncontrolled lateral displacement of the individual profiles can occur, causing misalignments of linearity at the ends.

To avoid this, we place **only** in the most centred clip, of each and every Annapurna 50x30 profile, the screw 7505A 2.5 x 25 mm as shown in the following image. This screw will fix the Annapurna profile to that clip, allowing its expansion and contraction, but avoiding its lateral movement.



In the following image, the clip in which the screw 7505A 2.5x25 mm would be placed in each and every profile is circled in red.

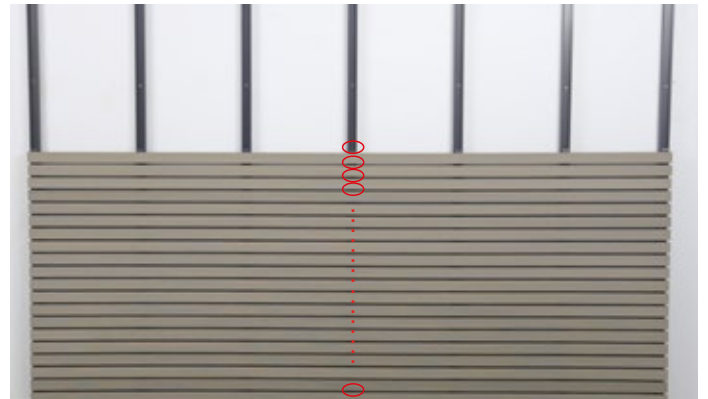

Taking into account all the instructions shown, all the necessary Annapurna profiles would continue to be installed until the installation is complete.

The following picture shows an example of a installation completed.



The Annapurna 50x30 mm profile can be installed using metal or concrete posts/pillars, installed or previously constructed on site, as a frame.



The site management must guarantee that the pipes or posts used as frames are suitable for the installation of the system. Tarimatec profiles are NOT structural.



In this case, we will use the Annapurna flat batten, whose measurements are 45x11 mm, shown in the following image.

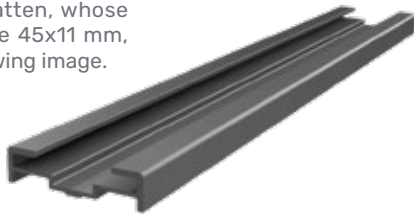

This strip shall be fixed to the posts with the fixings determined as appropriate by the project management, which must be compatible and not interfere with the Annapurna 50x30 mm installation system. The spacing between posts must not exceed 750 mm.

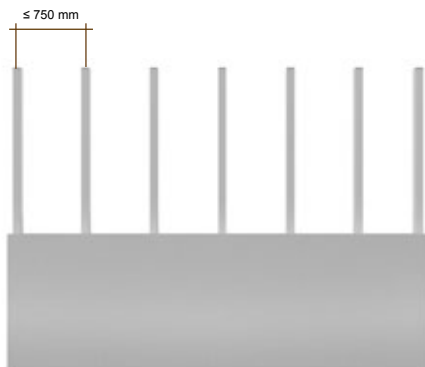

If this spacing is greater than 750 mm, and up to a maximum of 1.25 m, a compatible aluminium reinforcement profile must be incorporated into the installation. An example is shown:

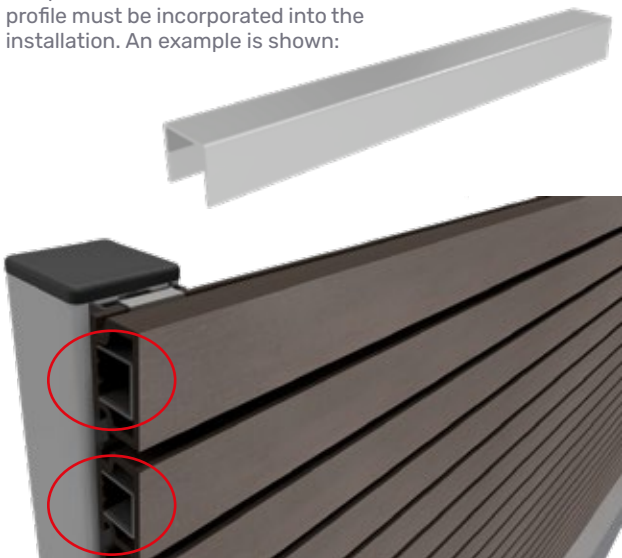

Once we have seen the peculiarities of the system in the described conditions, we start the installation. As an alternative to the starter clip, we can use an Annapurna clip, which can also be screwed to the batten. Before screwing, we drill a hole in the position of the hole with a 3.5 mm diameter metal drill bit and then fix the Annapurna clip to the strip with the 7504P 4.2x25 mm screw.



It is important to remember that screwing the clips to the batten is only necessary for the first row of clips, and then every 10 rows thereafter.

Once the clips of the first row are in place, we start the installation of the profiles, according to the installation system indicated above, so we would place the first Annapurna 50x30 mm profile and the corresponding clips, without fixing it to the strip.



As we already know, in the most centred clip of each and every one of the profiles, we would place the fixing screw of the clip to the Annapurna 50x30 mm profile.

We only place one screw per Annapurna profile, and the function of this screw is to prevent lateral displacement of the profiles, due to the expansion and contraction that the profile may undergo as a result of temperature variations.



We continue placing the Annapurna 50x30 mm profiles following the instructions given, and when we reach row 10, we place a level to ensure the horizontality or verticality of the installation (depending on whether the Annapurna profile is installed horizontally or vertically), and once the profile has been levelled, we screw the clip to the strip, in the same way as indicated above.

This step will be repeated every 10 rows (e.g. row 10, row 20, row 30... etc.) and before installation of the last row of the installation, i.e. in the penultimate row.



Once the last profile has been installed, the installation is complete.



Fixing the top row can be done using the starter clip.

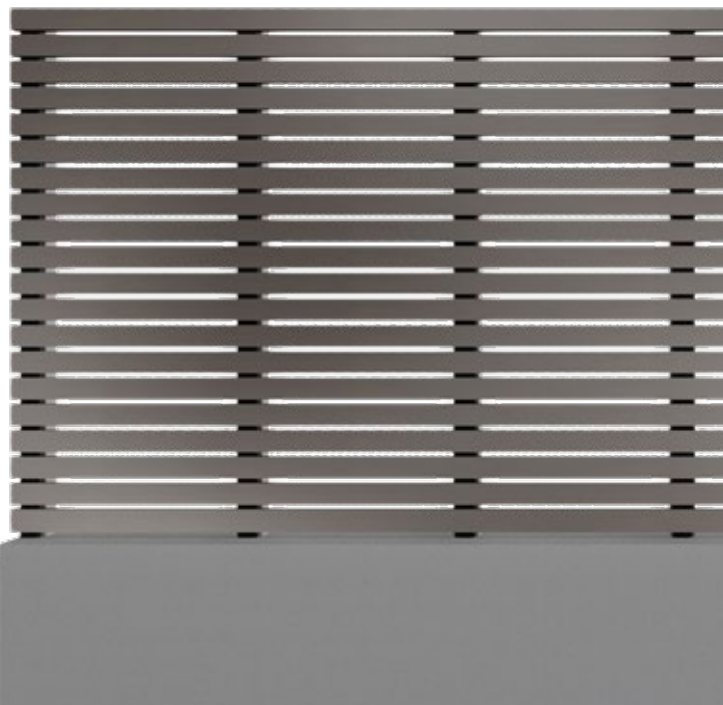

NOTES

VERTICAL SYSTEM

ANNAPURNA 50X30



Façade profile

ANNAPURNA PROFILE 50X30 mm

Dimensions and weight

	Value	Tolerance
Weight	860 g/mL	± 40 g/m
Width	50 mm	± 0.5 mm
Height	30 mm	± 0.5 mm
Length	3,000 mm	± 10 mm

18.2 mL / m². Custom length production, from 100 m², maximum length 4,000 mm.

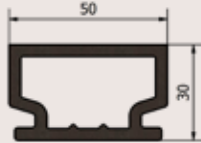

PHYSICAL AND MECHANICAL PROPERTIES	MET. TEST	VALUE
Coefficient of linear expansion	UNE 53126	2.84·10 ⁻⁵
Modulus of elasticity	UNE-EN ISO 178	4.675 Mpa
Bending strength	UNE-EN ISO 178	29.4 Mpa
Arrow at maximum force	UNE-EN ISO 178	2.9 mm
Brinell hardness	UNE-EN 1534	179.95 HB (N/mm ²)
Water absorption (24 h. in water at 20 °C ±2°C)	UNE-EN 317	0.99%
Water absorption (28 days in water at 20 °C ±2°C)	UNE-EN 317	1.78%
Temperature Vicat	UNE-EN ISO 306	87.4%
Density	UNE-EN ISO 1183-1	1.54 g/cm ³
Impact resistance	UNE-EN ISO 477	>5J
Determination of bending temperature under load	ISO 75-2 :2005	80.3±0.7°C
Resistance to salt spray Variation ΔE	UNE-EN ISO 9227	1.25 ΔE
Resistance to basidiomycete fungi	UNE-ENV 12038	Non-attackable
Resistance to basidiomycete soft rot fungus	CEN/TS 15083-2	Non-attackable
Classification of Reaction to fire	UNE-EN 13501-1:2007	B-s3, d0

END PROFILE



	Value	Tolerance
Weight	2,600 g/mL	± 100 g/m
Width	180 mm	± 5 mm
Height	10 mm	± 0.5 mm
Length	3,000 mm	± 10 mm

Façade profile

ANNAPURNA / MONT BLANC CONNECTING CLIP

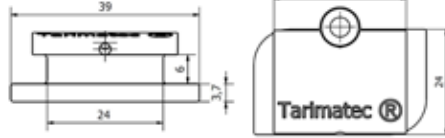

Made of PA 6.6 - High UV resistance

PROPERTIES	MET. TEST	VALUE
Density	ISO 1183	1.14 g/cm ³
Melting point	DSC	222 °C
Mould shrinkage	-	1 - 1.4 %
Tensile strength	ISO 527	85 MPa
Modulus of elasticity	ISO 527	2.900 MPa
Tensile modulus at strain	ISO 527	4.5%
Tensile modulus at break	ISO 527	35%
Temperature Vicat	UNE-EN ISO 306	206 °C
Water absorption (24 h. water at 23 °C)	UNE-EN ISO 62	2%
Impact resistance - 23 °C	ISO 180/A	>5.5 KJ/m ²

ALUMINIUM STRIP ANNAPURNA / MONT BLANC

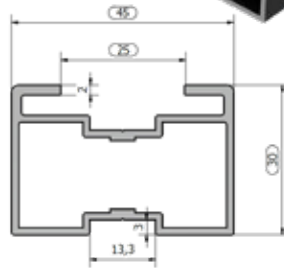
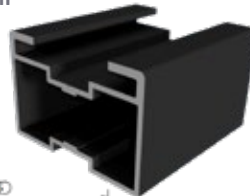

	Value	Tolerance
Weight	777 g/mL	± 50 g/m
Units / Box	20	-
Length	3,000 mm	± 10 mm

Si	Fe	Cu	Mn	Mg	Cr	Zn	Ti
0.50-0.90	0.35	0.5	0.5	0.40-0.70	0.30	0.20	0.10

Chemical composition: EN AW 6005 T6 Alloy
Alloy chemical composition
Standard S/EN 573-3

Mechanical Characteristics the UNE-EN 755 -2:2009 Standard is applied, EN AW 6005 for Treatment State T6 and thickness of measurements in mm < 5: Tensile strength (Rm) 255 Mpa / Elastic Limit (Rp0.2) 215 MPa / Elongation (A) 8 % / Applicable dimensional tolerances according to UNE-EN 755-9:200

FLAT ALUMINIUM STRIP 45x11 mm

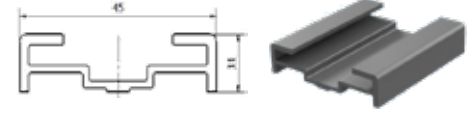

	Value	Tolerance
Weight	368 g/mL	± 15 g/m
Units / Box	20	-
Length	3,000 mm	± 10 mm

SCREW DIN 7504P A2 H 4,2X25 mm.



	Value	Tolerance
Units Box	200/1000	± 5 units.
Materials	Stainless steel. AISI - 304L *Stainless Steel. AISI - 316L	

*On request.

SCREW DIN 7505A A2 2.5 x 25 mm.



	Value	Tolerance
Units Box	200	± 5 units.
Materials	Zinc plating *Stainless Steel. AISI -304L	

*On request.

INITIAL CLIP

*On request.

	Value	Tolerance
Weight	16 g/units	± 0.5 g
Units	DEPENDING ON ORDER	-
Materials	Stainless steel. AISI - 304L *Stainless steel. AISI - 316L	

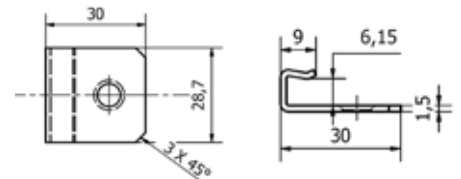

Available colours

Chromatic

Wengué	Miel	Moka	Marrón	Gris
2215	2214	2212	2213	2488

Wood

Nogal	Teka	Silver	Castaño	Roble	Ipe	Greenwood
2321	2326	2332	2333	2349	2348	2350

Polar	Sándalo	Luna	Cinnamon	Cozumel	Nielsen	Habanna
2347	2361	2364	2365	2377	2481	2482

There may be slight variations in the colour and surface finish, giving the decking a more natural finish. After a few months of exposure to the elements, as with wood, the colours lighten slightly, making the colour more uniform and stable

Composition

Tarimatec's raw material is ECO Fiber STONE, composed of PVC, rice husk and crushed marble. This makes a product that combines the best properties of both materials, guaranteeing a long life cycle, with no need for maintenance.

Environmental Information

Unlike other brands, the vegetable fibres used in the manufacture of the Tarimatec® cover do not come from the felling of trees, but are obtained from the reuse of by-products from the cultivation of cereals. It is totally recyclable.

*WARRANTY



Tarimatec® assumes a 25-year guarantee on its Deck, Mont Blanc, Annapurna and ARIS profiles, guaranteeing that they will not rot, splinter or disintegrate, nor will they be affected, in these terms, by the attack of insects or fungi.

In the event of any defect in the above, the warranty shall only cover the replacement of the affected profiles with the equivalent ones at the time of the complaint.

Any other possible compensation or claims relating to the disassembly and assembly of the replaced parts, transport or other costs resulting from the defective product are excluded.

The warranty does not cover damage to the product caused by incorrect use, overloading, incorrect installation and failure to comply with the assembly instructions, or the use of products other than the system, as well as any damage that the profiles may suffer due to exposure to the action of other elements or objects, as well as the use of cleaning products and/or elements not expressly named in the technical manual.

A slight lightening or change in colour will occur over time. This shall not constitute grounds for complaint.

This warranty will only be extended for installations fully assembled with the necessary and existing Tarimatec® accessories for each system.

In order to make a possible claim, the following must be submitted: purchase invoice, photographs of the defective parts and a description of the damage to your supplier.

****This warranty does not apply to the Finish product as to its durability, appearance and deterioration after installation, as all of these may depend on the type and frequency of use, weather, cleaning and any other factor that may affect its physical and mechanical properties.***

Project
Daar Architectura
Photograph
Álvaro Viera

